

# SCHMEISER

# VARITRAK



**T. G. SCHMEISER Co., Inc.**

## OPERATION AND PARTS MANUAL

Version 2.0  
September

*Read and understand the manual. This manual provides information and procedures to safely operate and maintain the Varitrak.*







## CONTENTS

<b>INTRODUCTION.....</b>	<b>4</b>	Adjust Wing Turnbuckle.....	20
Engineered for Long Life.....	4	Calibrate Wing Linkage.....	20
Serial Number Information.....	4	Initial Setup Checklist.....	21
Replacement Parts.....	4	Implement Break-In.....	21
Warranty Information.....	4	Connecting to Tractor.....	21
Serial Number Location.....	4	Detaching from Tractor.....	21
Factory Contact Information.....	4	Field Operation.....	22
Dealer Contact Information.....	4	Operation with a Laser System.....	22
<b>SPECIFICATIONS.....</b>	<b>5</b>	When Transporting Varitrak on the Road.....	23
<b>SAFETY.....</b>	<b>6</b>	<b>MAINTENANCE.....</b>	<b>23</b>
Safety Alert Symbols.....	6	Lubrication Points.....	23
Safety Icons Nomenclature.....	7	Wheel Hub Bearings.....	23
Personal Protection/Important Information..	7	Wing Linkage.....	23
Prohibited Actions.....	7	Service Items.....	24
Hazard Avoidance.....	7	Hydraulic Cylinders.....	24
General Safety.....	8	Hydraulic Hoses.....	24
Assembly Safety.....	8	Front 3-Pt. Linkage.....	24
Towing Safety.....	9	Tires.....	24
Highway and Transport Operations.....	10	Ground Engaging Components.....	24
Operation Safety.....	10	Bucket Blade.....	24
Tractor Requirements.....	10	S-Tines.....	24
Tractor Safety Devices.....	11	Maintenance Schedule.....	25
ROPS and Seat Belt.....	11	<b>STORAGE.....</b>	<b>26</b>
Attaching to Tractor.....	11	Storage Preparation.....	26
Prior to Connecting Unit.....	11	Placing in storage.....	26
Connecting to the Tractor.....	11	Removing From Storage.....	26
Hydraulic Component Safety.....	12	<b>PARTS SECTION.....</b>	<b>27</b>
Maintenance Safety.....	12	Component Nomenclature.....	27
Tires Safety.....	13	Ordering Parts.....	28
Tire and Lug Torque Specifications.....	13	Parts Drawings.....	28
Bolt Torque Requirements.....	13	Self-Leveling 3-Pt. Hitch Assembly.....	28
Welding Repairs.....	14	3-Pt. Hitch Laser Option Assembly.....	29
Storage Safety.....	14	Wing Linkage and Turnbuckle Assembly...	30
Disposal of Equipment at End of Useful Life.....	14	Sliding Plates Assembly.....	31
Safety Marking and Lighting.....	15	Dual Tire Frame Assembly.....	32
<b>SAFETY SIGNS AND DECALS.....</b>	<b>16</b>	Single Tire/Steel Wheel Frame Assembly..	33
Safety Sign Placement.....	16	Wing Bucket Assembly.....	34
Safety Signs and Decals.....	17	Rear Braces Assembly.....	35
<b>ASSEMBLY AND OPERATION.....</b>	<b>18</b>	S-Tine Attachment Assembly (Optional)..	36
Assembly Procedure.....	18	S-Tine Attachment Links Assembly (Opt.)..	37
Self-Leveling Hitch.....	18	S-Tine Assembly (Optional).....	38
Laser Control Kit (Optional).....	19	S-Tine Layouts (Optional).....	39
S-Tine Assembly (Optional).....	19	<b>HYDRAULIC DIAGRAMS.....</b>	<b>40</b>
Adjustment Procedure.....	20	<b>LIMITED WARRANTY STATEMENT.....</b>	<b>43</b>
Level Wings.....	20		

## INTRODUCTION

Your Schmeiser Varitrak (implement) is designed to provide many years of dependable service. This manual has been prepared to instruct the user in the safe and efficient operation of this implement. Read and understand the manual thoroughly and follow all instructions carefully.

### Engineered for Long Life

The Varitrak levels, smoothes, pulverizes the soil, fills depressions, and packs it all in one operation, helping save time and money. The Varitrak is extremely maneuverable in open field and orchard applications.

### Serial Number Information

Record the serial number, model number, and date purchased in the space provided in the Serial Number Location section. Be sure to have this information whenever contacting the dealer to order parts or attachments for this implement.

### Replacement Parts

Should this implement require replacement parts, contact your local Schmeiser dealer. Always order genuine Schmeiser OEM replacement parts.

### Warranty Information

It is important that the Warranty Card be completed and sent to Schmeiser. The warranty will not be valid until the information is on-file at Schmeiser. If information not contained in this manual is needed, contact your Schmeiser dealer.

Thank you for buying a Schmeiser Varitrak.

## Serial Number Location

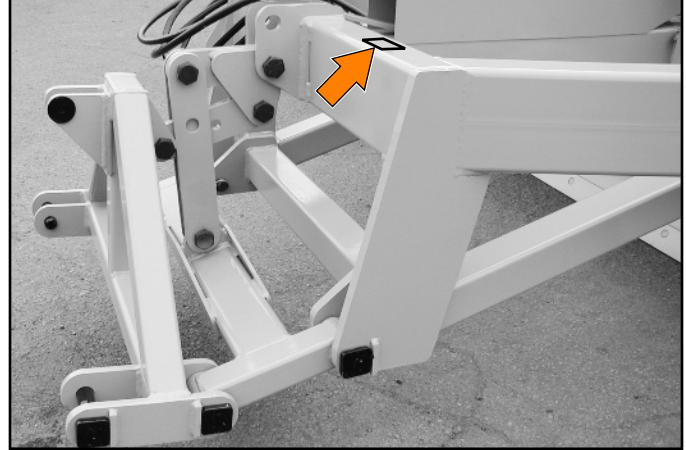

Serial No. \_\_\_\_\_

Model No. \_\_\_\_\_

Date Purchased. \_\_\_\_\_

Dealer Name. \_\_\_\_\_

### Factory Contact Information

For questions not answered in this manual, if additional copies are required, or the manual is damaged, please contact your local dealer or:

T. G. Schmeiser Co., Inc.  
P.O. Box 1392  
Selma, CA 93662

Phone: (559) 268-8128  
Fax: (559) 268-3279  
E-mail: sales@tgschmeiser.com  
Web: www.tgschmeiser.com

Additional copies of this manual can also be downloaded at [www.tgschmeiser.com](http://www.tgschmeiser.com).

### Dealer Contact Information

For replacement decals, questions, or to order parts, contact your dealer:



## SPECIFICATIONS

Model Number	Bucket Width	Rear Track	Weight
SVT-16R	16 Ft. (4.9 m)	Min. 9.0 Ft. (2.7 m) Max. 16.0 Ft. (4.9 m)	3600 lbs. (1633 kg)
SVT-16S	16 Ft. (4.9 m)	Min. 9.6 Ft. (3.0 m) Max. 16.0 Ft. (4.9 m)	3920 lbs. (1778 kg)
SVT-20R	20 Ft. (6.0 m)	Min. 9.0 Ft. (2.7 m) Max. 16.0 Ft. (4.9 m)	4440 lbs. (2011 kg)
SVT-20S	20 Ft. (6.0 m)	Min. 9.6 Ft. (3.0 m) Max. 16.0 Ft. (4.9 m)	4760 lbs. (2156 kg)
SVT-24R	24 Ft. (7.3 m)	Min. 9.0 Ft. (2.7 m) Max. 16.0 Ft. (4.9 m)	4587 lbs. (2078 kg)
SVT-24S	24 Ft. (7.3 m)	Min. 9.6 Ft. (3.0 m) Max. 16.0 Ft. (4.9 m)	4907 lbs. (2223 kg)
SVT-30R	30 Ft. (9.1 m)	Min. 9.0 Ft. (2.7 m) Max. 16.0 Ft. (4.9 m)	4812 lbs. (2182 kg)
SVT-30S	30 Ft. (9.1 m)	Min. 9.6 Ft. (3.0 m) Max. 16.0 Ft. (4.9 m)	5132 lbs. (2328 kg)

## Horsepower

	SVT-16R	SVT-20R	SVT-24R	SVT-30R
Minimum Drawbar	110 (82 kW)	130 (97 kW)	150 (112 kW)	190 (140 kW)
Recommended Drawbar	125 (93 kW)	150 (112 kW)	180 (134 kW)	200 (147 kW)

HP requirements for crawlers rated at 65% of above.

HP requirements for 4-wheel drive tractors rated at 85% of above.

## SAFETY

Carefully read and follow all safety precautions before operation. There are obvious and hidden potential hazards involved in the operation of this implement. Serious injury or death may occur unless care is taken to ensure the safety of both the operator and any other persons in the area. Avoid potential danger by taking extra time for thought and a more careful approach to the use of this implement.

Most work related accidents are caused by failure to observe basic safety rules or precautions. An accident can often be avoided by recognizing potentially hazardous situations before an accident occurs. As you assemble, operate, or maintain the unit, you must be alert to potential hazards. You should also have the necessary training, skills, and tools to perform any assembly or maintenance procedures.

Improper operation and maintenance of this unit could result in a dangerous situation that could cause injury or death. T.G. Schmeiser cannot anticipate every possible circumstance that might involve a potential hazard. The warnings in this manual and on the product are, therefore, not all-inclusive. If a method of operation not specifically recommended by us is used, you must satisfy yourself that it is safe for you and for others. You should also ensure that the unit will not be damaged or be made unsafe by the methods that you choose.

The information, specifications, and illustrations in this manual are based on the information that was available at the time this material was written and are subject to change without notice.

## Safety Alert Symbols



This is the safety alert symbol. It is used to alert you to potential personal injury hazards.

Obey all safety messages that follow this symbol to avoid possible injury or death.

This manual contains DANGERS, SAFETY INSTRUCTIONS, CAUTIONS, IMPORTANT NOTICES, and NOTES which must be followed to prevent the possibility of improper service, damage to the equipment, personal injury, or death. The following key words call the readers attention to potential hazards.

Hazards are identified by the "Safety Alert Symbol" and followed by a signal word such as "DANGER", "WARNING", or "CAUTION".

### **DANGER**

**Indicates an imminently hazardous situation which, if not avoided, will result in death or serious injury. This signal word is limited to the most extreme situations.**

### **WARNING**

**Indicates a potentially hazardous situation which, if not avoided, could result in death or serious injury.**

### **CAUTION**

**Indicates a potentially hazardous situation which, if not avoided, may result in minor or moderate injury.**

### **NOTICE**

**Indicates that equipment or property damage can result if instructions are not followed.**

### **SAFETY INSTRUCTIONS**

**Safety instructions (or equivalent) signs indicate specific safety-related instructions or procedures.**

**Note:** Contains additional information important to a procedure.

### Safety Icons Nomenclature

This manual and the equipment has numerous safety icons.

These safety icons provide important operating instructions which alert you to potential personal injury hazards.

### Personal Protection/Important Information

 READ THE MANUAL

 THINK SAFETY

 MAINTENANCE PROCEDURE

 WEIGHT RATING

 EYE PROTECTION

 HAND PROTECTION

 HEAD PROTECTION

 HEARING PROTECTION

 INSPECT EQUIPMENT

 OEM PARTS ONLY

 PLACE IN NEUTRAL

 PROTECTIVE SHOES

 REMOVE KEY

 DAMAGED HAZARD LABEL

 SLOW VEHICLE PLACARD

 SET PARKING BRAKE

 STOP ENGINE

 SUPPORT STAND USAGE

 USE PROPER TOOLS

 VISUALLY INSPECT

 USE ROPS

 USE CORRECT PARTS

### Prohibited Actions

 DO NOT ALTER OR MODIFY

 DO NOT LEAVE OUT TOOLS

 DO NOT WELD

 NO ALCOHOL

 NO CHILDREN

 NO DRUGS

 NO PASSENGERS

 NO RIDERS

 NO BYSTANDERS

### Hazard Avoidance

 BLOCK WHEELS

 CRUSHING HAZARD (body)

 CRUSHING HAZARD (foot)

 CRUSH HAZARD (rolling over)

 DEFECTIVE OR BROKEN PART

 FALLING HAZARD

 MAINTAIN SAFE DISTANCE

 OVERTURN HAZARD

 PINCH POINT HAZARD

 SAFETY ALERT SYMBOL

 SHARP OBJECT HAZARD

 ZERO PRESSURE

 COMPRESSED AIR HAZARD

 CRUSH HAZARD

 CRUSH HAZARD

 HIGH PRESSURE FLUID HAZARD

 HOT SURFACE HAZARD

 HEAVY OBJECT HAZARD



## GENERAL SAFETY



### WARNING



#### Read and Understand Manual

To prevent personal injury or even death, be sure you read and understand all of the instructions in this manual and other related OEM equipment manuals! This equipment is dangerous to children and persons unfamiliar with its operation. The operator should be a responsible adult familiar with farm machinery and trained in this equipment's operations. Do not allow persons to operate or maintain this unit until they have read this manual and have developed a thorough understanding of the safety precautions and how it works.

This unit was designed for a specific application;

DO NOT modify or use this unit for any application other than that for which it was designed.

Units operated improperly or by untrained personnel can be dangerous!



#### Fall Hazard

Do not use this implement as a work platform. Do not stand on top of the unit at any time. Do not ride on the tractor or the implement or allow others to ride.



#### Crush Hazard (Rolling Over)

To prevent serious injury or death, before disconnecting, leaving the operator's seat, servicing, adjusting, repairing, or performing other work on the implement, ALWAYS:

1. Stop the tractor or towing vehicle.
2. Shut off the engine and remove the ignition key.
3. Set the brakes.
4. Make sure wheel cylinder transport lock is attached.
5. Relieve hydraulic fluid pressure.



#### Injury Hazard

Do not permit children to play on or around the unit.



#### Impaired Operator Hazard

Do not attempt to operate this unit under the influence of drugs or alcohol. Review the safety instructions with all users annually.



#### Pinch Point /Sharp Object Hazard

Do not place any body parts between moving and / or stationary parts. The weight of the implement will easily cause serious bodily injury.



To prevent injury, use a tractor equipped with a Roll Over Protective System (ROPS).



#### Visually Inspect

Visually inspect the unit for any loose bolts, worn parts, or cracked welds, and make necessary repairs before using the unit.

#### Personal Protection Equipment

When working around or operating this unit, wear appropriate personal protective equipment. This list includes but is not limited to:



- A hard hat
- Protective shoes with slip resistant soles
- Protective goggles, glasses, or face shield
- Heavy gloves and protective clothing
- Ear muffs or plugs



#### Use Properly Rated Tools

To prevent serious injury: Use sufficient tools, jacks, and hoists that have the capacity for the job.



#### NO PASSENGERS ALLOWED

Do not carry passengers anywhere on or in the tractor or implement.



#### Rolling Hazard

To prevent serious injury, lock the wheels when performing assembly, maintenance, repairs, or when preparing for storage.

## ASSEMBLY SAFETY



### WARNING



#### Crush Hazard

Use support blocks or safety stands rated to support the load when assembling the unit or performing maintenance. Never work under equipment supported by hydraulics. Hydraulics can drop equipment instantly if controls are actuated even when power to the hydraulics is shut off.



#### Trapped Air Hazard

When installing, replacing, or repairing hydraulic system cylinders or parts, make sure that the entire system is charged and free of air before resuming operations. Failure to bleed the system of all air can result in improper machine operation, causing severe injury.



## TOWING SAFETY

### WARNING



#### Unexpected Separation Hazard

If the safety chain does not have a current certification tag, do not use the unit until properly certified chains are installed. Substandard safety chains could allow the unit to separate from the tow vehicle, resulting in equipment damage and personal injury.



#### Loss of Control

A minimum of 20% of the combined tractor and equipment weight should be on the front wheels to ensure adequate stability during transport and operation. To avoid serious injury or death from a loss of control accident, maintain 20% weight on the front wheels. Add front end weight if necessary.



Hitch and coupling on the towing vehicle must be rated equal to, or greater than, the unit's "gross vehicle weight rating" (GVWR).



Be aware of physical surroundings and especially bystanders, particularly children, before moving the unit! This is particularly important with higher noise levels and quiet cabs, as you may not hear people shouting.

Never use independent braking with unit in tow as loss of control and/or upset of unit may result.

Always drive at a safe speed relative to local conditions, and ensure that your speed is low enough for an emergency stop to be safe and secure. Keep speed to a minimum.

Reduce speed prior to turns to avoid the risk of overturning.

Avoid sudden uphill turns on steep slopes.

Always keep the tractor or towing vehicle in gear to provide engine braking when going downhill. Do not coast.

Watch for overhead obstructions and side clearances while transporting.

Always operate equipment in a position to provide maximum visibility at all times. Make allowances for increased length and weight of the equipment when making turns, stopping, etc.

## SAFETY INSTRUCTIONS



Towing the implement requires care! Both the implement and tow vehicle must be in good working condition. Securely attach the unit to the tow vehicle using a high strength, appropriately sized hitch pin with a mechanical retainer and attach the safety chain.



Check the tires for tread wear, inflation pressure, and overall condition before towing the unit.



Inspect the hitch and coupling for wear or damage. DO NOT tow the unit using a defective hitch or coupling!



Make sure the lug nuts holding the wheels are tight (torque to specifications) and that none are missing.



Do not allow anyone to stand between the tongue or hitch and the towing vehicle when backing up to the unit.

Operate the towing vehicle from the operator's seat only.



When transporting, remember the implement may be wider than your tractor and extreme care must be taken to allow for safe clearance.

## Highway and Transport Operations

### SAFETY INSTRUCTIONS



Do not exceed a towing speed of more than 20 mph (32 KPH) on a public roadway.

Tires supplied by the manufacturer are designed to operate NO MORE THAN 20 mph. Do not exceed the maximum speed or tire failure may occur.



When transporting the implement on public roads, use approved accessory lighting, flags, or other necessary warning devices to protect operators of other vehicles on the highway during daytime and nighttime transport. Various safety lights and devices are available from your dealer.



When towing the unit on public roads, use flashing amber warning lights and a slow moving vehicle (SMV) identification emblem. Make sure the SMV placard is clearly visible to vehicles approaching from the rear.

Some localities prohibit the use of flashing amber lights. Local laws should be checked for all highway lighting and marking requirements.

Be a safe and courteous driver. Always yield to oncoming traffic in all situations, including narrow bridges, intersections, etc. Plan your route to avoid heavy traffic.

Be observant of bridge load restrictions. Do not cross bridges rated lower than the gross weight at which you are operating.

Make sure the wheel lift cylinder transport locks are installed, and the jack stand is in its storage position before transporting the unit.

When transporting the implement on rough or uneven surfaces, drive slowly to prevent bouncing and loss of contact of the front wheels and the ground.

## OPERATION SAFETY



### WARNING



#### Crush Hazard (Rolling Over)

Do not clean, lubricate, or make adjustments while the unit is moving.



Never allow inexperienced or untrained personnel to operate the implement or tractor without supervision.



#### Enter And Exit Tractor

To avoid being run over, do not enter or exit tractor when it is moving. Avoid serious injury or death, from contact with rotating tires, by entering or exiting tractor only when it is completely stopped.



#### Safe Distance

Keep all bystanders, especially children, away from the tractor and implement during operation.



#### Overturn Hazard

Pick the most level route possible when transporting across fields. Avoid the edges of ditches, gullies, or steep hillsides. Be especially careful when turning on slopes with the wheels down. Never turn uphill with the wheels down except at slow speed and a low rate of turn. Never transport or operate this machine on steep slopes.

### SAFETY INSTRUCTIONS



Periodically clear the unit of brush, twigs, or other materials to prevent buildup of dry, combustible materials.



Visually check all fasteners for tightness or damage before and after operation. Repair immediately if required.

## Tractor Requirements



### WARNING



#### Tractor Owner/Operator Manual

Always refer to the tractor Operator's Manual to ensure compatibility and maximum safety.

Be familiar with the location, settings, and function of the tractor controls before using this equipment.

### SAFETY INSTRUCTIONS

Do not use a tractor of more than the recommended HP to prevent damaging implement components.

## Tractor Safety Devices

If transporting or operating the tractor and implement near a public roadway, the tractor must be equipped with proper warning lighting and a Slow Moving Vehicle (SMV) emblem, which are clearly visible from the rear of the unit. Lights and a SMV emblem must be attached directly to the implement if the visibility of the tractor warning signals is obscured.

Never operate the tractor PTO with the PTO master shield missing or in the raised position.

## ROPS and Seat Belt

The tractor must be equipped with a Roll Over Protective Structure (ROPS) (tractor cab or roll-bar) and seat belt to protect the operator from falling off the tractor, especially during a roll-over where the driver could be crushed and killed.

Only operate the tractor with the ROPS in the raised position and seat belt fastened.

### **WARNING**



#### **Rollover Hazard**

To avoid serious injury or death from falling off tractor, equipment runaway, rollover, or crushing:

- 1) Use ROPS equipped tractor.
- 2) Keep ROPS locked in the UP position.
- 3) Only operate the equipment when seated in the tractor seat.
- 4) Always fasten seat belt when operating the tractor and Implement.

## Attaching to Tractor

### Prior to Connecting Unit

Make sure the unit is resting on the ground or the transport lock is securely installed over the wheel cylinder rod before attaching the unit to the tractor.

### Connecting to Tractor

### **WARNING**



#### **Crush Hazard**

Use care when attaching the unit to the tractor. Never place any part of your body under the tongue or hitch assembly.

Do not allow anyone to stand between moving tractor and implement during hook-up operations.



#### **Unexpected Separation Hazard**

If towing the unit with a drawbar, use only a certified, hardened drawbar pin with a retainer clip. Do not use homemade pins, bolts, or any other type of retaining device. Always install the retainer clip, making sure the hitch and unit are securely fastened to the tow vehicle.

Using a pin not intended for this type of towing can result in unexpected separation of the unit from the tow vehicle, resulting in equipment damage and personal injury.

## **SAFETY INSTRUCTIONS**

Connect implement hitch to the tractor properly.

## Hydraulic Component Safety



### **WARNING**



#### **High-Pressure Fluid Hazard**

Before applying pressure to the system, make sure all components are tight and that the hydraulic lines, hoses, fittings, and couplings are not damaged.



#### **Hydraulic Pressure**

This unit operates with hydraulic pressures of 2500 to 3000 psi (170 to 205 bars).

#### **High-Pressure Fluids**



1. Check or tighten all connections BEFORE pressurizing system.



2. Release all pressure before removing hoses and/or valves by:

- a. Stopping engine.
- b. Holding hydraulic control levers in float or neutral position.



3. DO NOT use your bare hand to check for potential leaks. Always use a board or cardboard when checking for a leak.

Escaping hydraulic fluid under pressure, even a pinhole size leak, can penetrate body tissue, causing serious injury and possible death. If fluid is injected into your skin, it must be treated immediately by a doctor familiar with this type of injury.



## WARNING



Wear proper hand and eye protection when searching for a high-pressure hydraulic leak.

Use a piece of wood or cardboard as a backstop instead of hands to identify and isolate a leak.

If injured by a concentrated high-pressure stream of hydraulic fluid, seek medical attention immediately. Without immediate medical treatment, serious infection or toxic reaction can develop if hydraulic fluid penetrates the surface of the skin.



### Trapped Air Hazard

When installing, replacing, or repairing hydraulic system cylinders or parts, make sure that the entire system is charged and free of air before resuming operations. Failure to bleed the system of all air can result in improper machine operation, causing severe injury.



### High-Pressure Separation Hazard

Replace any worn, cut, abraded, flattened, or crimped hoses.



### Zero Pressure

Relieve pressure from the hydraulic system before servicing or disconnecting from the tractor.



### High-Pressure Hazard

Do not make any temporary repairs to the hydraulic lines, fittings, or hoses using tape, clamps, or cement. The hydraulic system operates under extremely high pressure and temporary repairs may fail suddenly and create a hazardous/dangerous situation.



## CAUTION



### Explosive Separation Hazard

Be sure all hydraulic pressure is relieved before disconnecting hydraulic lines or fittings between implement and the tractor hydraulic system.

## NOTICE

Make sure components in the hydraulic system are kept clean and in good working condition.

## MAINTENANCE SAFETY



## WARNING



### Use Properly Rated Tools

Use sufficient tools, jacks, and hoists that have the capacity for the job.



### Crush Hazard

Use support blocks or safety stands rated to support the load when performing maintenance.

## SAFETY INSTRUCTIONS

Follow all operating, maintenance, and safety instructions found in this manual.



Understand the service procedure before performing the work. Keep area clean and dry.



Keep all parts in good condition and properly installed. Fix damage immediately. Replace worn or broken parts.



Do not leave tools lying on the unit.



Do not modify unit or safety devices. Do not weld on the unit. Unauthorized modifications may impair its function and safety.

If equipment has been altered in any way from the original design, the manufacturer does not accept any liability for injury or warranty.



Never replace hex bolts with less than Grade 5 bolts unless otherwise specified. In locations where Grade 8 bolts are used, Grade 8 replacements are required.



Where replacement parts are necessary for periodic maintenance and servicing, genuine factory replacement parts must be used to restore the unit to original specifications.

The manufacturer will not accept responsibility for damages as a result of the use of unapproved parts.

### Tires Safety

#### **WARNING**



#### **Explosive Separation Hazard**

Do not attempt to mount a tire onto a wheel unless you have the proper equipment and experience to do the job. Failure to follow proper procedures when mounting a tire on a wheel can produce an explosive separation, which may result in serious injury or death.



#### **Explosive Hazard**

Never weld or heat a wheel and tire assembly. The heat can cause an increase in air pressure, resulting in a tire explosion. Welding can structurally weaken or deform the wheel.



#### **Flying Objects Hazard**

Inflating or servicing tires can be dangerous. Whenever possible, trained personnel should be called to service and/or mount tires.

When inflating tires, use a clip-on chuck and extension hose. Always stand to the side of the tire when inflating, and NOT in front of or over the tire assembly. Make sure the tires are inflated evenly.

### SAFETY INSTRUCTIONS



Always maintain the correct tire pressure. Do not inflate the tires above the recommended pressure.



Check tires for low pressure, cuts, bubbles, damaged rims, or missing lug bolts or nuts.



Keep wheel lug nuts or bolts tightened.



Always install replacement tires and wheels with appropriate capacity to meet or exceed the weight of the unit.

### Tire and Lug Torque Specifications

Tire Size	Ply Rating	Lug Size	Lug Torque (lb.ft.)
7.6 x 15	8 Ply	1/2"	80
9.5 x 15	8 Ply	1/2"	80
12.5 x 16	14 Ply	9/16"	70

### Bolt Torque Requirements

It is extremely important to apply and maintain proper torque on all bolts. Use a torque wrench to assure the proper amount of torque is being applied to the fastener. Start all bolts or nuts by hand to prevent cross threading.

Torque figures indicated in the chart are used for non-greased or non-oiled threads unless otherwise specified. Therefore, do not grease or oil bolts or cap screws unless otherwise specified in this manual. When using locking elements, increase torque values by 5%.

The chart gives correct torque values for various bolts and cap screws. Tighten all bolts to the torques specified in the chart unless otherwise noted. Check tightness of bolts periodically, using the bolt torque chart as a guide. Always replace hardware with the same Grade bolt.

#### **WARNING**



#### **Equipment Failure**

The torque value for bolts and cap screws are identified by their head markings. Replacing higher "Grade" bolts (Grade 5) with lower Grade bolts will lead to equipment failure and can result in injury or death. Always use replacement bolts with the same Grade markings as the removed bolt.

Bolt Diameter	Bolt Torque Specifications			
	Grade 5		Grade 8	
	N·m	ft.lbs.	N·m	ft.lbs.
1/4"	12	9	17	12
5/16"	25	19	36	27
3/8"	45	33	63	45
7/16"	72	53	100	75
1/2"	110	80	155	115
9/16"	155	115	220	165
5/8"	215	158	305	220
3/4"	390	290	540	398
7/8"	570	420	880	650
1"	850	630	1320	970



## Welding Repairs



Before performing any type of welding repair to the implement, contact T.G. Schmeiser Co., Inc. for approval. Repair welding must be done with care and with procedures that may be beyond the capabilities of the ordinary welder.



### WARNING



#### Personal Injury Hazard

Repairs or modifications to the implement can result in serious injury or death should these repairs fail.

## NOTICE

Anyone performing a welding repair should be certified in accordance to the American Welding Society (AWS) standards.

## STORAGE SAFETY



### WARNING



#### Hazard And Information Signs

Replace any missing or hard-to-read safety signs. Safety sign placement and part numbers can be found in the Nomenclature section of this manual.



#### Damaged Parts Hazard

Do not use this unit if it is in need of repair. If you believe the unit has a defect which could cause damage, injury, or death, you should immediately stop using the unit.

## SAFETY INSTRUCTIONS



Store the implement in an area away from human activity.



Do not permit children to play on or around the stored unit at any time.



Block the wheels to prevent the implement from rolling.



When using compressed air to clean implement, wear safety glasses.

## DISPOSAL OF EQUIPMENT AT END OF USEFUL LIFE

The T. G. Schmeiser implement has been designed for the specific purpose of conditioning the ground in agricultural applications. When this unit is no longer capable of doing its designed purpose, it should be dismantled and scrapped. Do not use any materials or components from this unit for any other purpose.



### Safety Marking and Lighting

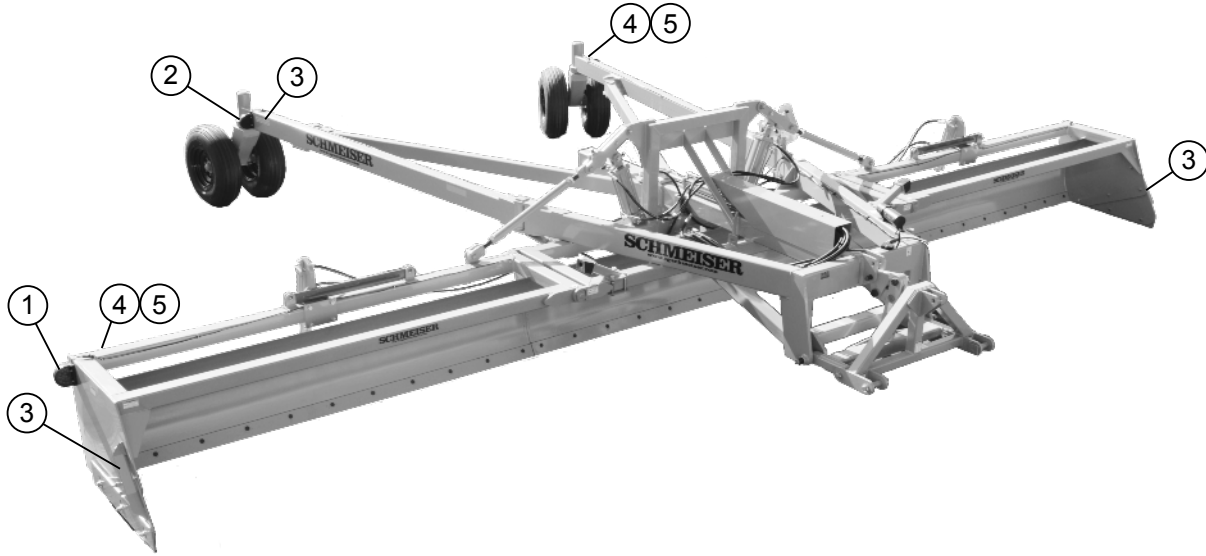

### Safety Lights Wiring Diagram

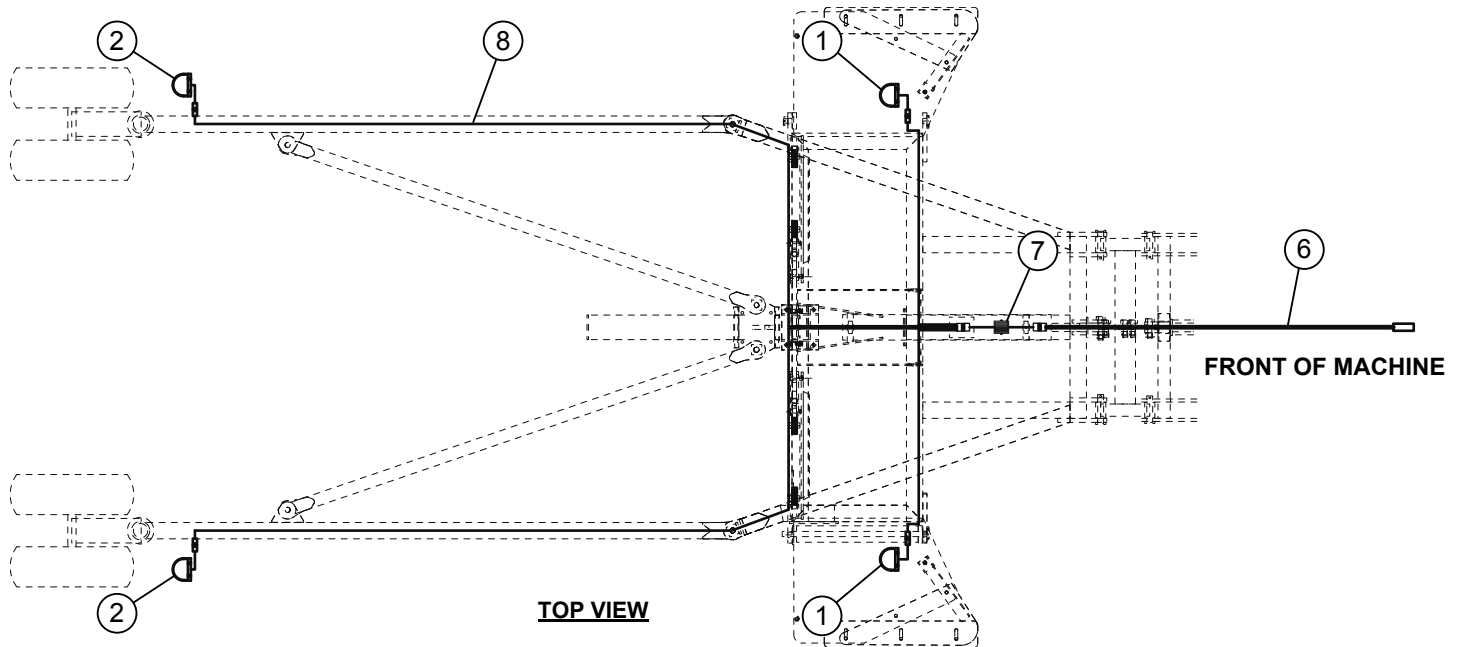

##	Part Number	Description	Q'ty
1	GLT-LSDY	Lamp, Surface Mount Double Yellow	2
2	GLT-LSSR	Lamp, Surface Mount Single Red	2
3	D-2X9RY	Reflective Tape, Yellow	6
4	D-2X9RR	Reflective Tape, Red	2
5	D-2X9FL	Fluorescent Tape, Orange	2
6	GLT-HF07	Front Harness, 7 Ft. Long	1
7	GLT-FCM	Flasher Control Module	1
8	GLT-HW5050	Rear Wishbone Harness 50 Ft.-50 Ft.	1

## SAFETY SIGNS AND DECALS

### SAFETY INSTRUCTIONS

Follow all operating, maintenance, and safety instructions found in this manual.



Replace all worn or damaged safety and instruction decals.

- It is the responsibility of the customer to know the marking requirements of the local highway authorities and to comply with the regulations.
- Keep safety signs clean and legible at all times. Replace safety signs that are missing or have become illegible.
- Do not paint over, remove, or deface any safety signs or instructional decals on your equipment. Observe all safety signs and follow the instructions on them.
- When parts that display a safety sign are replaced, the replacement part should display the same sign.
- Make sure the safety signs and other instructional decals are legible and attached to the unit before use.
- Safety signs are available from your Distributor, Dealer Parts Department, or the factory.
- Use care when washing or cleaning the unit not to remove or damage the labels.
- Locations for the labels and replacement part numbers are shown in this section.

### Safety Sign Placement

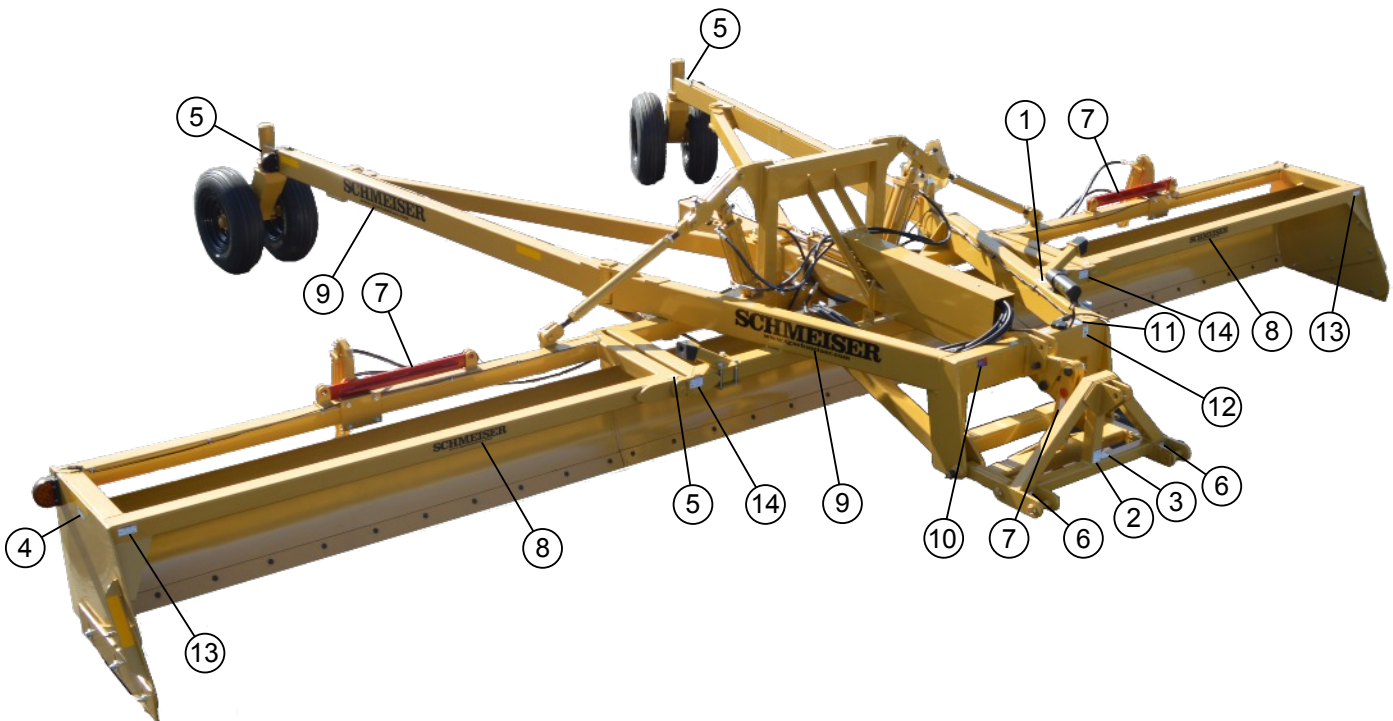

**Safety Signs and Decals**

Item	Part Number	Description	Qty.
1	D48X038RTM	Read the Manual	1
2	D48X038CRR	Crush / Rollover Hazard	1
3	D48X064HPF	High Pressure Fluids	1
4	D28X048SCE	Sharp Object Hazard	2
5	D16X026GRS	Grease Decal	8
6	D28X048PPT	Pinch Point	2
7	D28X048RBW	Transport Lockout	3
8	D32X208TGS	Schmeiser 2" X 13"	4
9	D104608BLK	Schmeiser 6-1/2" X 38"	4
10	D32X048RBC	Made in the USA	1
11	D48X48QR	Scan to Access Online Manual	1
12	DFEMALOGO1	FEMA	1
13	D28X048ECH	Electrocution Hazard	2
14	D28X048CRH	Crush Hazard - Danger	2

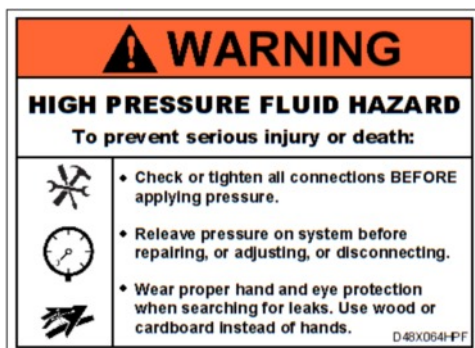
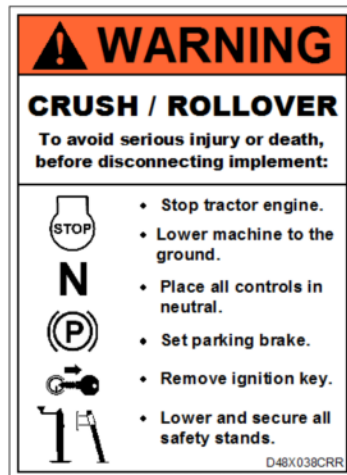
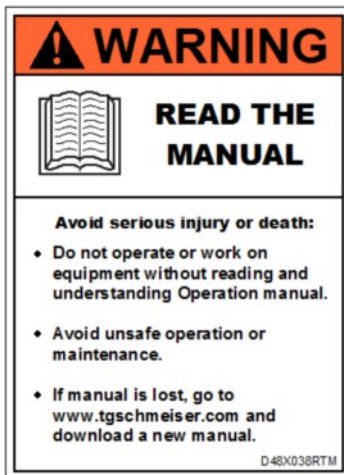

## ASSEMBLY AND OPERATION



### WARNING



#### Understand Safety Procedures!

Read and understand all safety procedures described in this manual before performing any work on or around the implement.

### Assembly Procedure

1. Select a smooth, level area approximately 40 feet wide and 40 feet long.
2. Position main frame on the ground and center it in the area with the open bucket facing the direction that the machine is to be pulled.
3. Position and attach rear slide tube (SVT-00B300) to the main frame with (4) 3/4" x 2-1/2" NC Cap Screws and (4) 5/8" x 2" NC Cap Screws with lock washers and hex nuts. See page 31.
4. Install Slide Plates assembly on slide tube. Refer to page 31 drawing for proper installation.

*Note: Make sure slide plates and slide roller holes align before installing. Do not attempt to force pins through slide rollers.*

5. Attach rod end of 3" x 36" Hydraulic Cylinder to the slide plate cylinder anchor using 1" cylinder pin and hair pin clips. Attach other end to the main frame cylinder anchor using 1" cylinder pin and hair pin clips.
6. Hoist and attach left wing and right wing with wing hinge pins, slotted nuts, and cotter pins. See page 34 for reference.
7. Install wing linkage assemblies. Refer to page 30 drawing for proper installation.
  - a. Install wing turnbuckle assemblies as follows:
    - Attach turnbuckle clevis end to wing anchor using 1" x 3-1/2" bolts and nylon lock hex nuts. Tighten enough to allow free movement.
    - Attach turnbuckle single plate end to wing linkage weldment with 1" x 3-1/2" bolts and nylon lock hex nuts. Tighten enough to allow free movement.
  - b. Attach rod end of 4" x 12" hydraulic cylinder to the wing linkage center plate (SVT-00F001). Attach other end to the main frame. Repeat for the other side.
  - c. To level wings, see Calibration Instructions on pages 20.

8. Hoist and attach primary brace LH and primary brace RH to the main frame using 1-1/4" x 11" pins with slotted nuts and cotter pins. Refer to page 35 for details.
9. Attach rear wheel frames with rubber tires to the main braces as shown on page 32 (double tires) and 33 (single tire).
10. If the optional steel wheels are ordered, attach wheel scraper arms RH and LH to rear wheel frames (forks). Attach scraper blades to scraper arms. See page 33.

### 11. Installation - Self-Leveling Hitch

- a. Position hitch top link in the lower of the top main frame holes. Secure with 1-1/4" x 5-1/2" shoulder bolt and 1-1/4" nylon lock hex nut making sure not to damage self-lubricating bushings. Install short link according to the picture below.

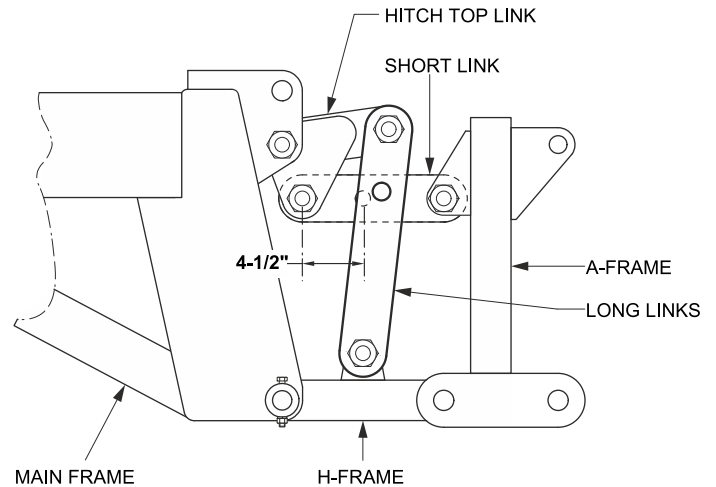

- b. Position H-Frame with the bottom holes on main frame and attach with 1-1/2" x 8" pin, bushing, 3/8" x 3" bolt with lock washer and hex nut.
- c. Position A-Frame on H-Frame and fasten with two 1-1/2" x 6-1/4" pins and lock in position with 1/4" lynch pins.
- d. Position short link between top link and A-Frame and install each end (being careful not to damage self-lubrication bushings) with 1-1/4" x 3-3/4" and 1-1/4" x 4-1/2" shoulder bolts and nylon lockhex nuts.
- e. Position RH and LH long links between H-Frame and top link and secure each end with 1-1/4" x

4-1/2" shoulder bolt. Install 1-1/4" nylon lock hex nuts. Tighten enough to allow free movement.

- f. Attach self-leveling hitch to tractor's hitching points. Adjust tractor top link until hitch A-Frame is vertical.

12. Connect the four hydraulic lines to tractor lines and check for leaks. Go back over the entire leveler to check and securely tighten all nuts and bolts. Before starting operation, grease all grease fittings with good quality grease.

### Installation - Laser Control Kit (Option)

1. Remove the top link, short link, and long link from the self-leveling hitch.
2. Install the cylinder attaching anchor in the two upper holes of the main frame, use 1-1/4" X 5-1/2" NC bolts with lock washers and hex nuts.
3. Connect the front hydraulic cylinder barrel end to the cylinder attaching anchor and the rod end on hydraulic cylinder to the hole on the H-Frame with the cylinder ports facing to the right. See page 29 for details.
4. Attach the laser stand to the main frame. The slotted holes are for leveling the top of the laser stand.
5. Check the complete hydraulic system for leaks under pressure and complete the assembly of laser control components. After testing, install all shields and covers.

**NOTE:** Make sure all pivot points on the hitch fit tightly so that the laser system has no false motion for which to compensate.

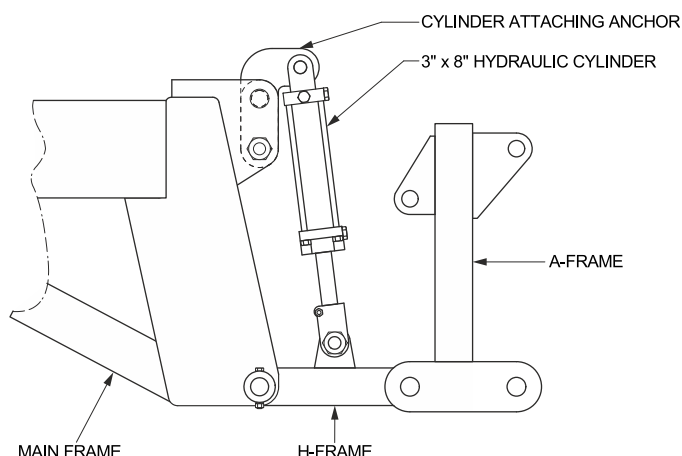

### Installation - S-Tine Assembly (Option)

1. Attach S-Tine assembly frames to the rear attachment plates of the buckets using link plates with holes and 3/4" x 2" Gr. 5 bolts with nylon lock hex nuts. Install S-Tines on the frames according to S-Tine diagram on page 39. Refer to page 38 for S-Tine assembly details.

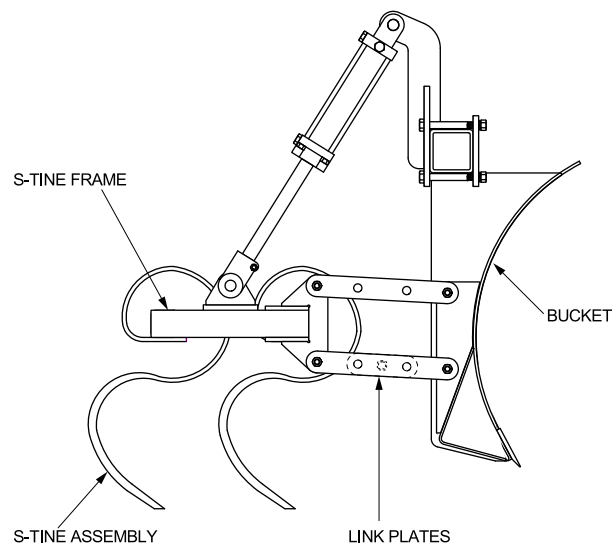

2. Install large cylinder anchors on all three bucket frames using clamp plates and 5/8" X 6" Gr.5 bolts with lock washers and hex nuts.
3. Attach series tie rod hydraulic cylinders. Refer to hydraulic diagram on page 41 for details.
4. Connect barrel ends to the large cylinder anchors mounted to the buckets, and rod ends - to small cylinder anchor mounted to S-Tine frames. See diagram below and pages 36-37 for details.

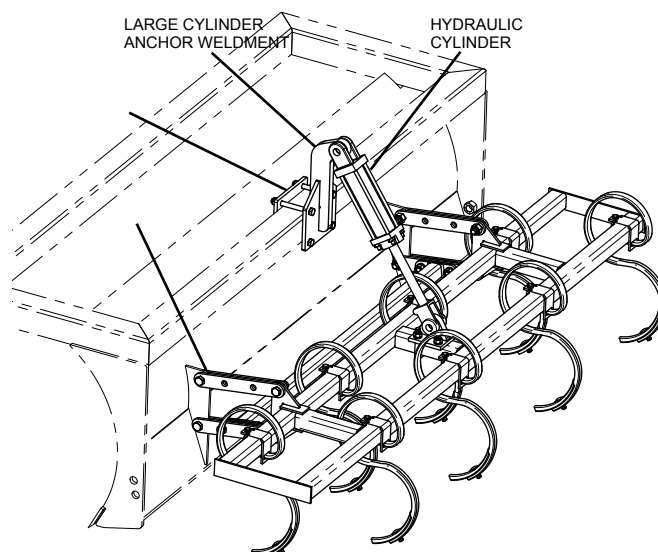



5. Place small cylinder anchor weldments on the S-Tine frames as follows:

- wing frames - right in the middle on the cross brace using 5/8" U-bolts with lock washers and hex nuts.
- main bucket frame - offset from the center to the right side using auxiliary brace bolted to the S-Tine frame and 5/8" U-bolts with lock washers and hex nuts.

See the drawing below.

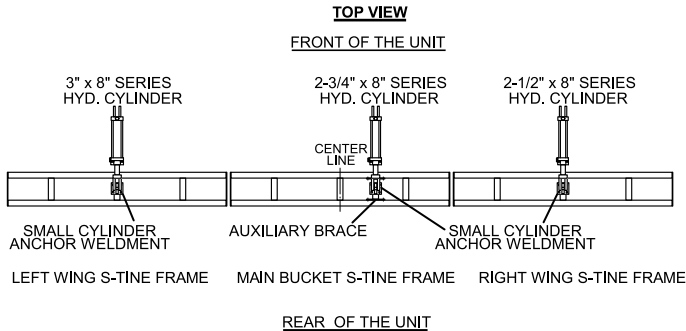

## Adjustment Procedures

### LEVEL WINGS

1. Ensure that the main frame is leveled using bubble level.
2. Back out wing adjustment set screws. Using a hoist or a forklift, and a bubble level, set wings to level.
3. Screw in adjustment set screws until it makes firm contact with wings. Lock in place with jam hex nuts.

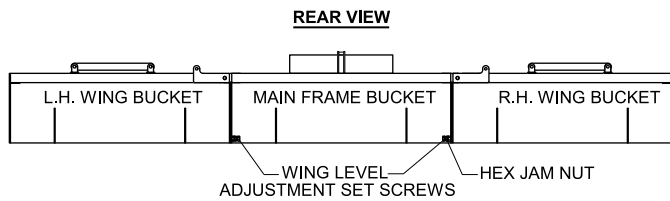

### ADJUST WING TURNBUCKLES

1. Back out wing turnbuckle jam nut.
2. Rotate wing turnbuckle until pivot point is 1/4" to 3/4" past centerline. Use string to determine distance.

See picture below.

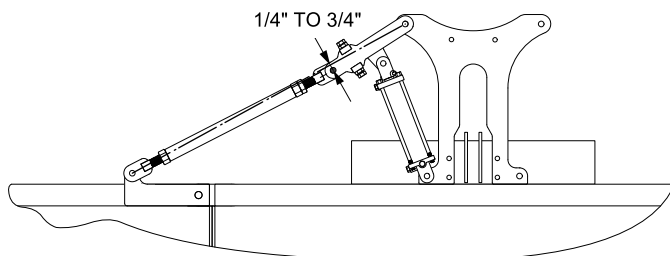

### CALIBRATE WING LINKAGE

1. Unlock wing linkage jam nuts and back out wing linkage set screws, but don't remove them.

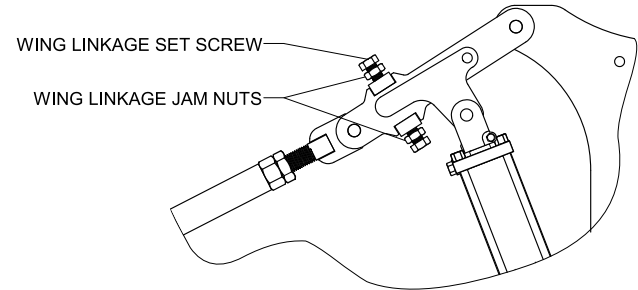

2. Using a hoist or a forklift, raise wings to approximately 90 degrees and ensure that lockout plates fit easily.

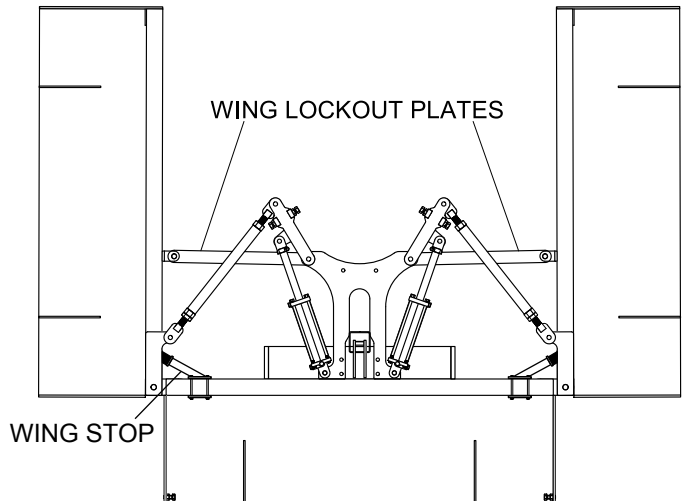

Move wing stops to make contact with folded wings and tighten in place (for 30 Ft. units).

3. Screw in wing linkage set screws until they hit center linkage plate. Lock in place with jam nuts.

Repeat on the other side.

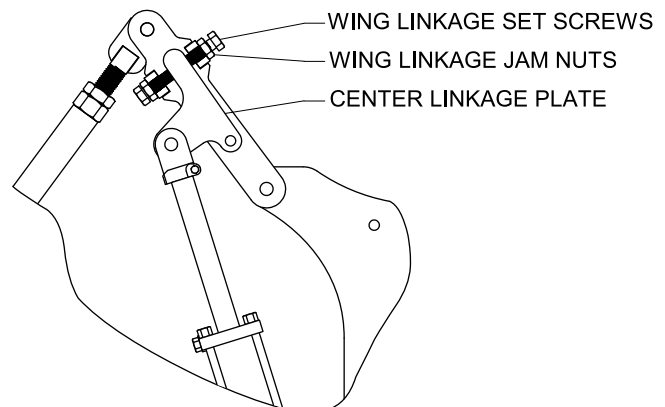









### Initial Setup Checklist

Efficient and safe operation of the implement requires that every user read and understand the operational instructions and all related safety instructions outlined in this manual.

This checklist is provided for the user/owner. It is important for both personal safety and to maintain the mechanical condition of the implement that this checklist is followed.

Initial Setup Checklist (prior to using for the first time)	
Location	Task
	Make sure the Implement is properly attached to the tractor. Refer to "Attaching to Tractor" on page 11.
	Make sure all hardware is properly installed and tightened. Refer to "Maintenance" on page 13.
	Check the condition of the blades for wear, hydraulic hoses for leaks. Replace if necessary.
	Lubricate all grease fittings. Refer to "Lubrication Points" on page 23.

### Implement Break-In

Although there are no operational restrictions on the Implement when used for the first time, it is recommended that the following mechanical items be checked:

1. After 1/2 hour of operation:
  - a. Check all fasteners and tighten if necessary.
  - b. Make sure that the ring roller is in good condition.
2. After 10 hours of operation:

- a. Go to the normal servicing and maintenance schedule, as defined in the Maintenance Section.

### Connecting to the Tractor

Make sure the unit is resting on the ground before attaching the unit to the tractor.

1. Remove the lynch pins and lift pins.
2. Board the tractor and start the engine. Position the tractor with the 3-point lift arms positioned at the same height and aligned with the Varitrak hitch pin holes.

*Note: Set the 3-point lift control to "Position Control" so that the lift arms maintain a constant height when attaching the Varitrak. See the tractor Operator's Manual for correct settings when attaching 3-point equipment.*

3. Turn off the tractor engine and dismount.
6. Insert the hitch pin through the lift arm and lug holes and install the lynch pin.
7. Walk around to the opposite side and repeat the procedure for the remaining lift arm and hitch pin.
8. Extend or retract the 3-point top link to align its end hole with the hole of the Varitrak top link. Insert the top link hitch pin and insert the lynch pin into the hitch pin.
9. Return to the tractor and slowly raise the 3-point lift arms fully up and down to make sure the Varitrak does not make contact with the tractor tire, draw bar, or any other equipment on the tractor.

*NOTE: Move or remove the draw bar if it interferes with the implement.*

10. Connect the hydraulic hoses to the proper ports on the tractor.

### Detaching From Tractor

1. Park the tractor, place the transmission in park or neutral, and apply the parking brake. Shut down the engine, relieve all hydraulic pressure, and remove the key before exiting the tractor.
2. Block the wheels to prevent movement.

INSTALL RED LOCK PIN PROVIDED PRIOR TO DISCONNECTING FROM TRACTOR TO PREVENT A-FRAME FROM FALLING.

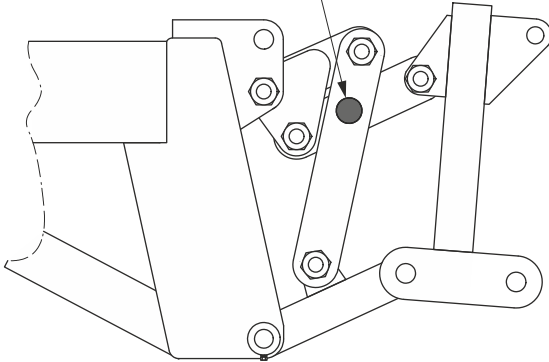

3. Disconnect the hydraulic hoses from the tractor. Coil the hoses and store them on top of the implement.
4. Extend or retract the tractor 3-point hitch top link to remove tension on the top link hitch pin. When the pin is loose and easy to rotate, remove the pin from the Varitrak.
5. Disconnect the lift arms and drive the tractor away from the Varitrak.

## FIELD OPERATION

1. Adjust the bucket blade height with the tractor's 3-point hitch hydraulic control. This will determine the load that will be carried in the bucket. The recommended load is to have the bucket 2/3 full in operation.
2. After the blade height has been set, adjust the center link of the tractor's 3-point hitch so the H-Frame is parallel to the ground. This is required to obtain the maximum compensation in leveling. Whenever the working height of the blade is changed, the center link should be readjusted to keep the H-Frame parallel to the ground.
3. The top link of the 3-point hitch should be adjusted so that the A-Frame of the self-leveling hitch is perpendicular to the ground. This is necessary to get the maximum compensation (travel) in leveling.
4. The width of the rear wheel tread can be adjusted while in motion but should not extend past the bucket ends. This allows wide lateral stability and land leveling and narrow tread width while turning in a corner or along a ditch or levee.

5. The bucket wings can be raised and lowered hydraulically. When in the down position, they are mechanically locked rigid for land leveling. There are holes for a bolt near the bottom and in the back of the bucket that can be used to hold the bucket wings down if the hydraulic lines are disconnected.
  - a. There is an adjusting screw near the bottom and in the back of the bucket roll on each side. This is for adjusting the bucket wings level with the center section. Always make sure that all three buckets are in line.
  - b. The large turnbuckles on each wing lock must be adjusted to hold the bucket wings down tight when in locked position. There are two adjusting screws on each lift lock that are used to adjust the hydraulic cylinder stroke to lock the hydraulic cylinder pins about 1/4" to 3/4" past center.

This will hold the bucket wings in a locked position with no pressure on hydraulic lines.

6. Traversing ditches that are over three feet wide and twelve inches deep or crossing levees over twelve inches in height at a ninety-degree angle to the ditch or levee **SHOULD BE AVOIDED**. If this cannot be avoided, the top link of the tractor's 3-point hitch should be disconnected to prevent the self-leveling hitch from exceeding its travel limits and becoming damaged. It is recommended in crossing a ditch or levee that the tractor and the land leveler approach at an approximate forty-five degree angle to allow the self-leveling hitch to operate most efficiently.
7. When lowering the bucket wings, be sure that the center bucket section is clear of the ground so that dirt is not trapped between the buckets sections. Dirt will prevent the buckets from lining up and forcing the sections will damage the bucket lift mechanism.

## Operation with a Laser System

1. Level the laser stand by loosening the four cap screws and using a carpenter's level on the top plate of the laser stand. Retighten when level.
2. Adjust the tractor's 3-point hitch so that the tractor lift links are parallel to the ground.
3. Lengthen top link on the tractor until there is from 1-3/4" to 2" of down stroke on 3 x 8 cylinder.



Make sure all pivot points on the hitch fit tightly so that the laser system has no false motion for which to compensate.



### WHEN TRANSPORTING VARITRAK ON THE ROAD

1. When transporting the Varitrak Land Leveler with the tractor, the center link of the 3-point hitch must be disconnected; otherwise, the hitch may be damaged if the travel limits of the hitch are exceeded. Fold rear wheel braces before transporting.

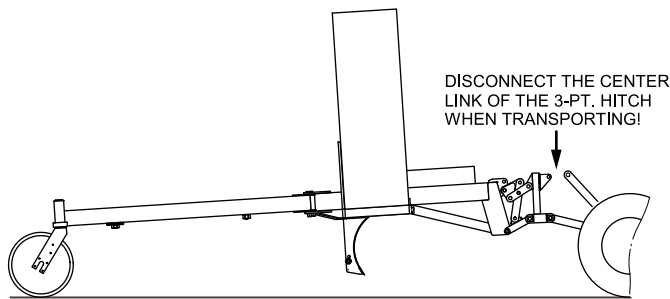

2. The two bucket wings are equipped with lockout plates. They must be used when the bucket wings are in the raised position before attempting to transport. This will prevent accidental lowering of the bucket wings.

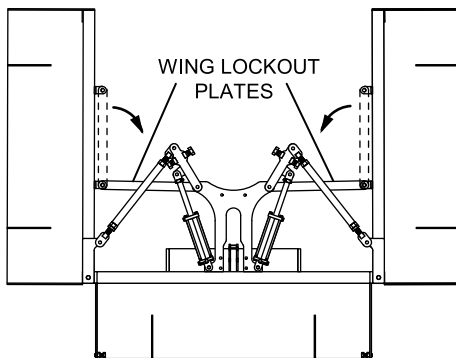

## MAINTENANCE

### **WARNING**



#### Understand Safety Procedures!

Read and understand all safety procedures described in this manual before performing any work on or around the implement.

#### Lubrication Points

Add grease to the locations shown.

#### Rear Wheel Frame Bearing Housing

Re-pack with grease once a week.

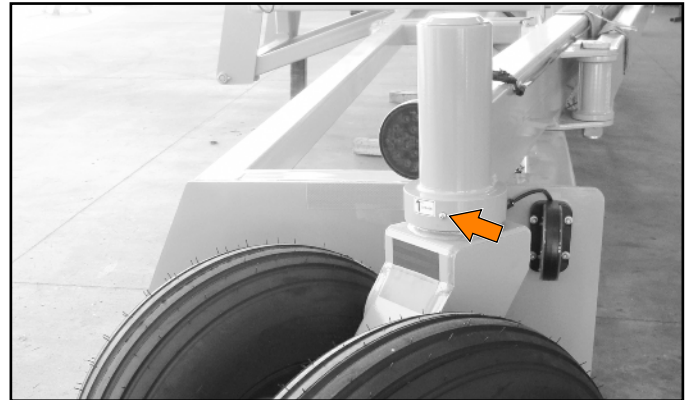

#### Wheel Hub Bearings

Re-pack with grease once a season – inspect bearings and races for wear and replace if necessary.



#### Wing Linkage

Grease every 40 hours or weekly with a good quality all purpose grease.

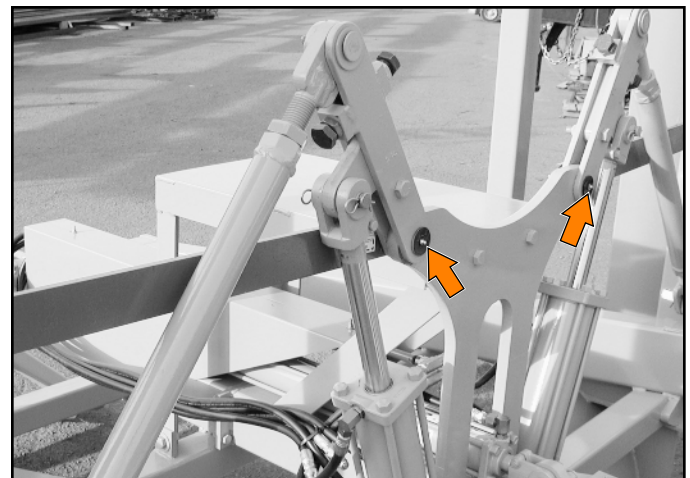



## Service Items

### Hydraulic Cylinders

Visually inspect for leaks and replace fittings or/and seals if necessary.

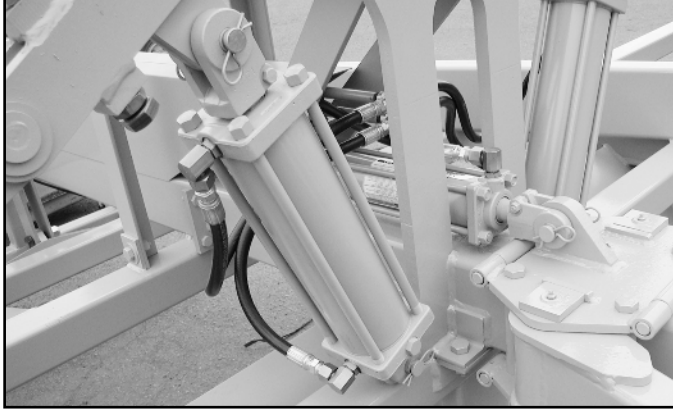

### Hydraulic Hoses

Inspect all hydraulic hoses and fittings for leaks or signs of wear. Replace any that are overly worn or damaged.



### Tires

Check tire pressure and set to tire manufacturer's recommended specifications. Inspect the tires for wear and/or damage. Make sure the wheel lugs are tightened to the proper torque.



### Front Linkage

Visually inspect and replace when worn or damaged or any pins are missing.



### Ground Engaging Components

#### Bucket Blades

Ground engaging components are subject to abrasion and wear. Excessively worn components will require replacement.

Replace the blades when they are worn out.

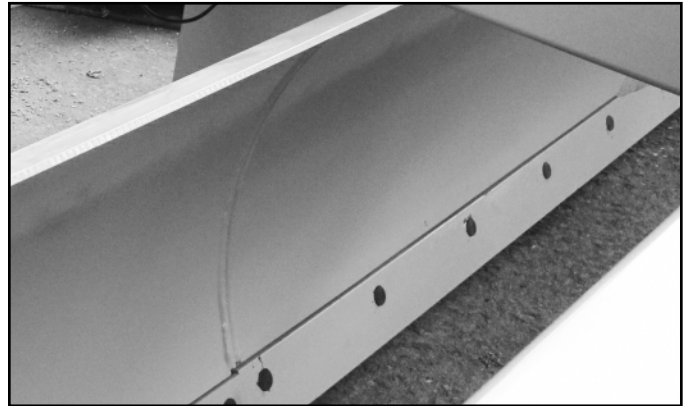

#### S-Tines (Optional)

Visually inspect S-Tines for wear and damage. Replace any excessively worn or damaged S-Tines.





**Maintenance Schedule**

The period recommended is based on normal operating conditions. Severe or unusual conditions may require more frequent service.

Copy this page to continue the record.

Hours and Serviced By																				
<b>Maintenance</b>																				
<b>Before Each Use</b>																				
Ensure that all fasteners are tight, and all pins are secured in place.																				
Inspect the frame for structural fractures.																				
Make sure all warning decals are in place and legible.																				
Inspect all hydraulic hoses and fittings for leaks or signs of wear.																				
Check bucket blades for wear and damage. Replace if necessary.																				
Lubricate zerk fittings on hinge plates and turnbuckles with a good general purpose grease.																				
<b>Every 50 Hours or Weekly</b>																				
Perform the Daily Maintenance schedule.																				
Lubricate zerk fittings on hinge plates and turnbuckles with a good general purpose grease.																				
Check tire pressure and set to tire manufacturer's recommended specifications. Inspect the tires for wear and/or damage. Make sure the wheel lugs are tightened to the proper torque. Refer to "Tire and Lug Torque Specifications" on page 13.																				
<b>Every 1000 Hours or Annually</b>																				
Perform the Daily Maintenance schedule.																				
Perform the Weekly Maintenance schedule.																				
Lubricate zerk fittings on the transport wheel bearing hubs with a good quality wheel bearing grease. Fill each cavity just until resistance is felt. Do not force grease past the seals.																				
Remove debris and clean the entire implement with compressed air or a pressure washer.																				
Remove rust and apply a coat of paint to frame surfaces where the paint has been worn off or damaged.																				

## STORAGE

### Storage Preparation

After Varitrak field work is completed for a season, perform the following maintenance procedures before storing the implement.

1. Check all bolted connections. Ensure that the fasteners are tight, and all retaining pins are secured in place with appropriate retaining clips.
2. Check the tire pressure and set to the tire manufacturer's recommended specification. Inspect the tires for wear and/or damage. Make sure the wheel lugs are properly tightened. Refer to "Tire and Lug Torque Specifications" on page 13.
3. Inspect the frame for structure fractures and inspect the side wing pivot points for wear or damage.
4. Check all the bearings for signs of seal damage or excessive wear.
5. Inspect all the hydraulic hoses and fittings for leaks or signs of wear.
6. Check the ring rollers for wear and damage. If any roller teeth are excessively worn or damaged, they must be replaced.
7. Make sure all the warning decals are in place and legible. Replace any worn decals as needed.
8. Remove debris and clean the entire implement with compressed air or low pressure water.

## NOTICE

To help prevent damage, avoid spraying air, water, steam, or cleaning solvents directly at the bearings and seals.

9. Lubricate all grease fittings on the frame members with a good general purpose lithium grease. Refer to "Lubrication Points" on page 21 for the location of the fittings.
10. Add grease to the fittings on the transport wheel bearing hubs with a good quality wheel bearing grease. Fill each cavity just until resistance is felt. Do not force grease past the seals.
11. Apply a thin layer of grease or rust preventative to all exposed metal surfaces of the cylinder rods.
12. To help prevent corrosion, remove rust and apply a coat of paint to frame surfaces where paint has been worn off or damaged.

### Placing in storage

1. Raise the implement, place the side wings in the transport mode, and install the transport lock.

2. Move the Varitrak to a storage area with a firm and level base to prevent it from tipping or sinking into the ground. For best results, always store the Varitrak in a dry, protected location. Leaving this implement unprotected will shorten the service life.
3. Disconnect all hydraulic hoses, and unhitch the implement from the tractor. Refer to "Detaching From Tractor" on page 20.
4. Store the implement with the transport wheels extended in the transport mode and the transport lockouts secured in place. Do not leave the tractor attached to the implement while in storage.

### Removing From Storage

Each season, perform the following inspection and maintenance before using the unit.

1. Read the operator's manual to review all safety, operational, and maintenance procedures.

**NOTE:** Store the operator's manual in the document storage canister located on the main frame.

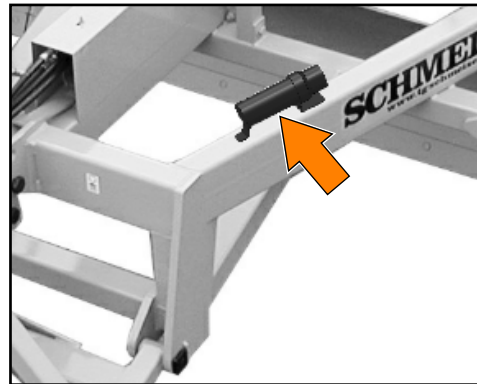

2. Perform any recommended maintenance that was not completed when the implement was put into storage.
3. Visually inspect the implement for wear or damage.
4. Check the tire pressure and set to the tire manufacturer's recommended specification. Inspect the tires for wear and/or damage.
5. Inspect all the hydraulic hoses and fittings for leaks and signs of wear or damage.
6. Make sure all the warning decals are in place and legible. Replace any damaged or missing decals.
7. Hitch the implement to a tractor and connect all hydraulic hoses. Refer to "Connecting to Tractor" on page 21. Place the implement in an area clear of overhead obstructions or power lines. Cycle the hydraulic system circuits to phase (synchronize) the hydraulic cylinders, verify proper operation, and check for leaks.



## COMPONENT NOMENCLATURE

### Component Locations

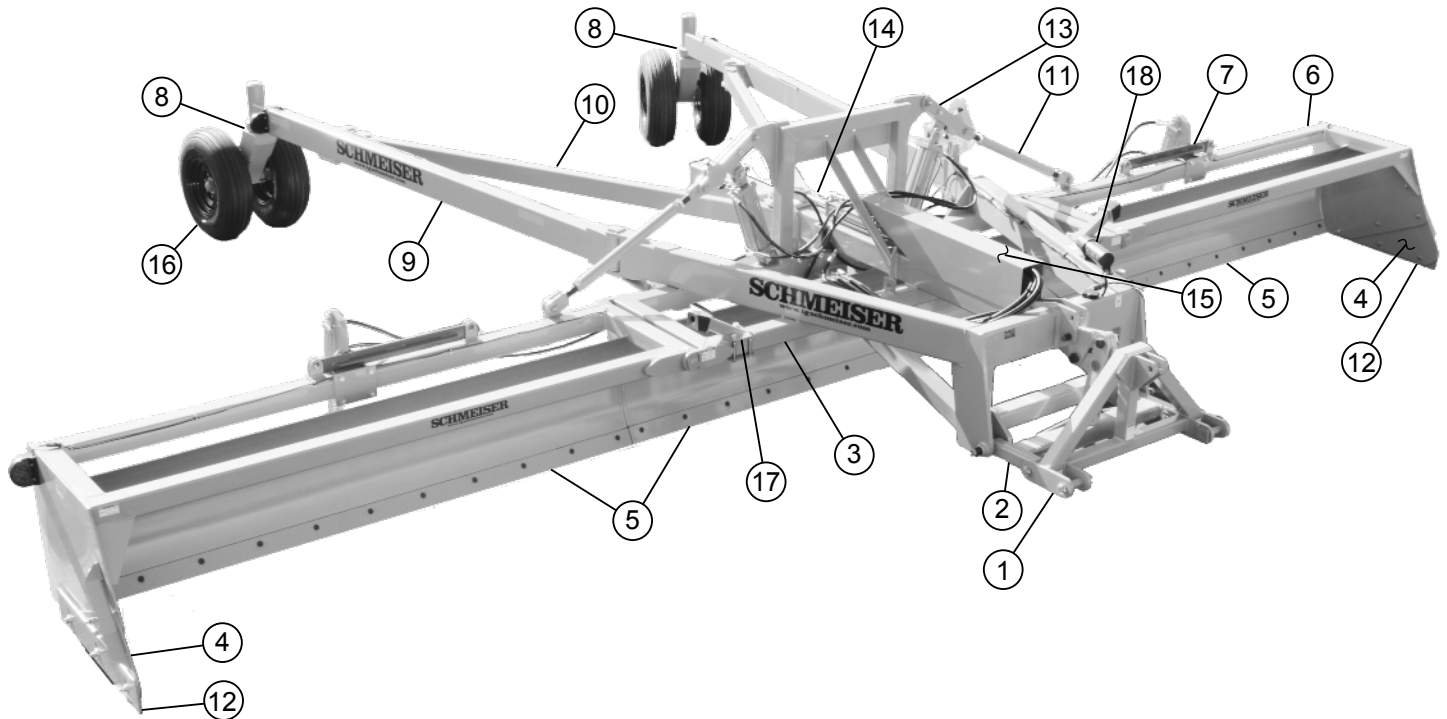

Item	Part Number	Description	Qty
1	SVT-00A100	Front "A"-Frame	1
2	SVT-00A500	"H"-Frame	1
3	SVT-08B100	8 Ft. Main Frame Bucket	1
	SVT-10B100	10 Ft. Main Frame Bucket	1
4	SLP-00L200L	Bucket Side LH	1
	SLP-00L200R	Bucket Side RH	1
5	SVT-BK3824	Bucket Blade Kit for 24 Ft. Units (includes blades and fasteners)	1
	SVT-BK3830	Bucket Blade Kit for 30 Ft. Units (includes blades and fasteners)	1
6	SVT-08D100	8 Ft. Wings (pair)	1
	SVT-10D100	10 Ft. Wings (pair)	1
7	SVT-00D200	Wing Transport Lockout	2
8	SVT-00G000	Steel Wheel / Single Tire Wheel Frame (Optional) - shown	2
	SVT-00G100	Dual Tire Wheel Frame	2
9	SVT-00C100	Rear Main Brace	2
10	SVT-00C200	Rear Secondary Brace	2
11	SVT-00K000	Wing Turnbuckle	2
12	SLP-00L204	Bucket Side Adjustment Blade	2
13	SVT-00F000	Wing Linkage (see p. for details)	2
14	SVT-00E100	Top Sliding Plate (see p. for details)	1
	SVT-00E200	Bottom Sliding Plate (see p. for details)	1
15	SVT-00B122	Hydraulic Hose Cover	1
16	GWT-111408	11L X 14 Tire with Wheel (single tire option)	2
	GWT-951508	9.5 X 15 8 Ply Tire with Wheel (double tire option)	4
	SLP-00D000	30" Steel Wheel (Optional)	2
17	SVT-00D300	Varitrak Wing Stop Assembly (30 ft. Units only)	2
18	OMC1	Owner Manual Canister	1

## Ordering Parts

We manufacture a quality product that requires very little maintenance or repair. However, should a part break or become damaged, our knowledgeable staff can make sure you receive the part(s) to put your unit back into operation.

## Parts Drawings

### Varitrak Self Leveling 3-Pt. Hitch Assembly

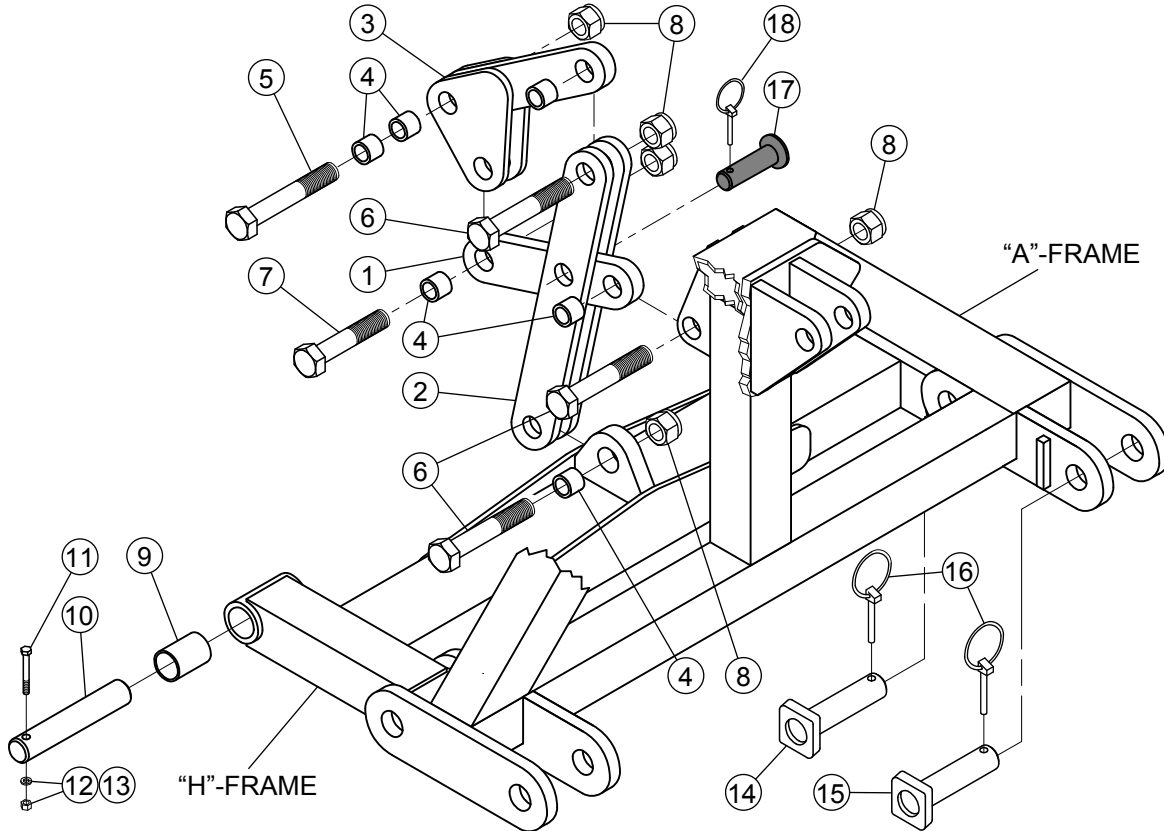

Item	Part Number	Description	Qty
1	SVT-00A200	3-Pt. Hitch Short Link	1
2	SVT-00A300	3-Pt. Hitch Long Link	2
3	SVT-00A400	3-Pt. Hitch Top Link Weldment	1
4	GBR-2024G16	1-1/4" X 1-1/2" X 1" Self Lubricating Bushing	6
5	SVT-00A302	1-1/4" X 5-1/2" NC Long Shoulder Bolt	1
6	SVT-00A303	1-1/4" X 4-1/2" NC Long Shoulder Bolt	3
7	SVT-00A304	1-1/4" X 3-3/4" NC Long Shoulder Bolt	1
8	NYNUT-20NC	1-1/4" NC Nylon Lock Hex Nut	5
9	GBR-2428G60	1-3/4" X 1-1/2" X 3-3/4" Self Lubricating Bushing	4
10	SVT-00A600	Varitrak Main Frame Pin	2
11	CSNC506048	3/8" X 3" Gr.5 NC Cap Screw	2
12	HXNUT-06NC	3/8" NC Hex Nut	2
13	LWASHER-06	3/8" Lock Washer	2
14	SVT-00A700	"A"-Frame to "H"-Frame Pin	2
15	SVT-00A900	"A"-Frame Front Pin	2
16	GPN-070LYN	7/16" Lynch Pin	4
17	GPN-16X048	1" X 3" Red Lock Pin	1
18	GPN-040LYN	1/4" Lynch Pin	1

**3-Pt. Laser Option Assembly**

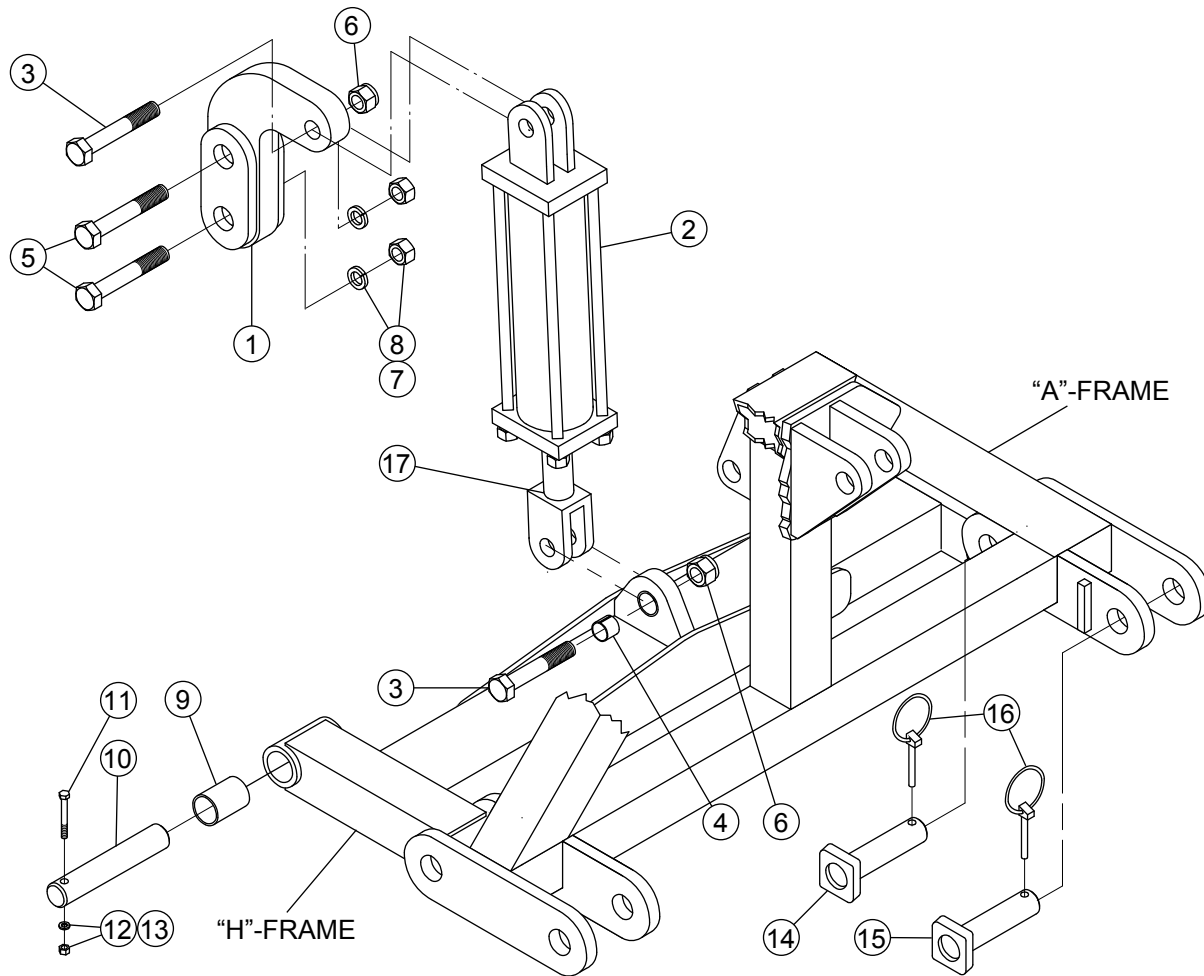

Item	Part Number	Description	Qty
1	SVT-00A800	Laser Option Cylinder Anchor	1
2	GHC-30080T	3" X 8" Tie Rod Hydraulic Cylinder	1
3	CSNC516072	1" X 4-1/2" Long Shoulder Bolt	2
4	GBR-20X16T	1-1/4" X 1" X 1" Tension Bushing	1
5	CSNC520088	1-1/4" X 5-1/2" NC Long Shoulder Bolt	2
6	NYNUT-16NC	1" Nylon Lock Hex Nut	2
7	LWASHER-20	1-1/4" Lock Washer	2
8	NYNUT-20NC	1-1/4" NC Nylon Lock Hex Nut	2
9	GBR-2428G60	1-3/4" X 1-1/2" X 3-3/4" Self Lubricating Bushing	4
10	SVT-00A600	Varitrak Main Frame Pin	2
11	CSNC506048	3/8" X 3" Gr.5 NC Cap Screw	2
12	HXNUT-06NC	3/8" NC Hex Nut	2
13	LWASHER-06	3/8" Lock Washer	2
14	SVT-00A700	"A"-Frame to "H"-Frame Pin	2
15	SVT-00A900	"A"-Frame Front Pin	2
16	GPN-070LYN	7/16" Lynch Pin	4
17	PMCK33000	Seal Kit for 3" X 8" Hydraulic Cylinder	1

### Wing Linkage and Turnbuckle Assembly

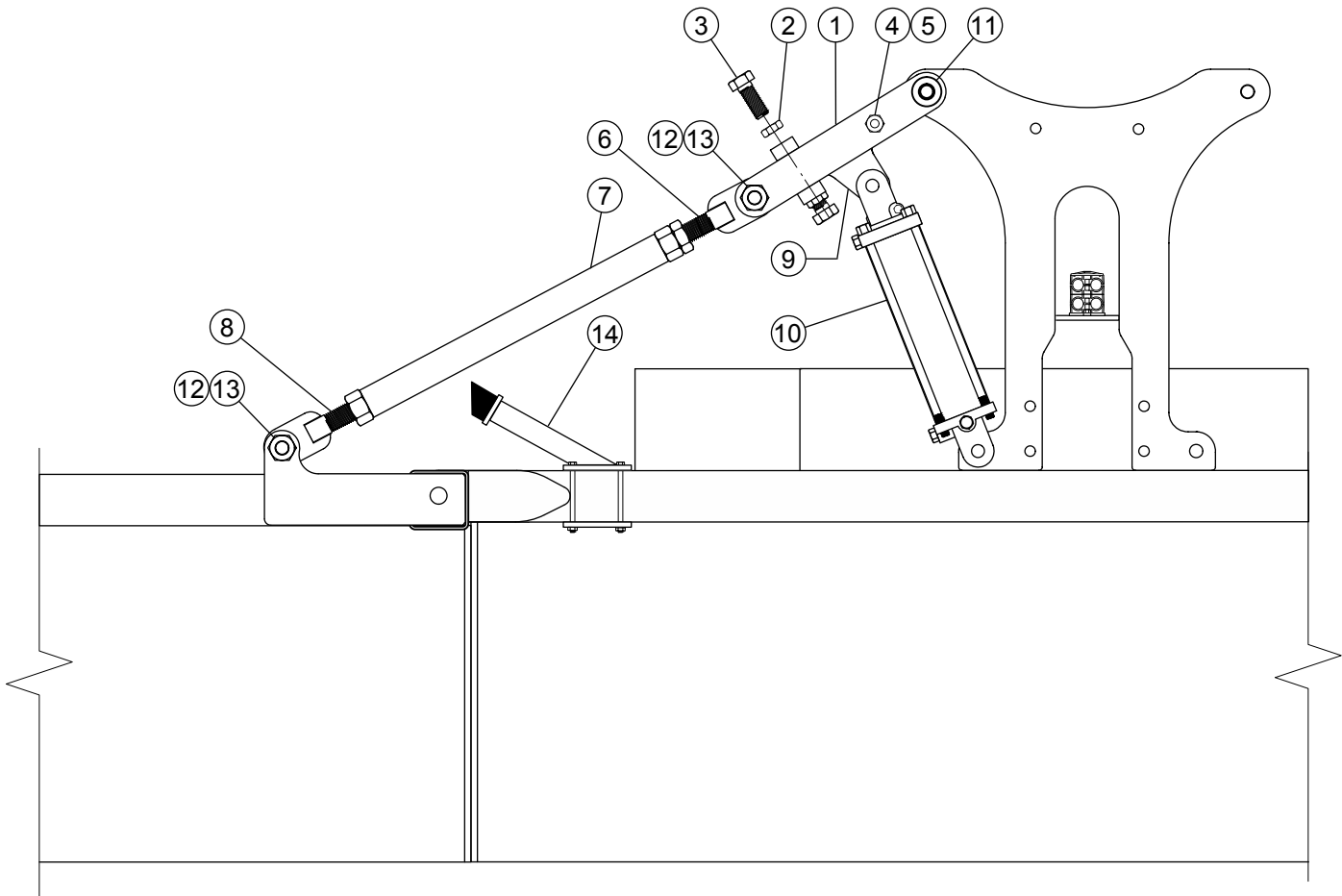

Item	Part Number	Description	Q'ty
1	SVT-00F000	Wing Linkage	2
2	HXNUTJ16NC	1" NC Hex Jam Nut	4
3	CSNC816040	1" X 2-1/2" Gr.8 Cap Screw	4
4	CSNC508048	1/2" X 3" Gr.5 Cap Screw	2
5	NYNUT-08NC	1/2" NC Nylon Lock Hex Nut	2
6	SVT-00K200	Turnbuckle Top RH Thread Rod	2
7	SVT-00K100	Turnbuckle Body	2
8	SVT-00K300	Turnbuckle Bottom LH Thread Rod	2
9	SVT-00F001	Wing Linkage Center Plate	2
10	GHC-40120T	4" X 12" Tie Rod Hydraulic Cylinder	2
11	SVT-00F003	Wing Linkage Pin	2
12	CSNC516056	1" X 3-1/2" NC Cap Screw	4
13	NYNUT-16NC	1" NC Nylon Lock Hex Nut	4
14	SVT-00D300	Wing Stop Assembly (includes fasteners - 30 Ft. Units only)	2
	SVT-F	Wing Linkage Assembly (includes items 1, 2, 3, 4, 5, and 9)	
	SVT-K	Turnbuckle Assembly (includes items 6, 7, and 8)	

**Sliding Plates Assembly**

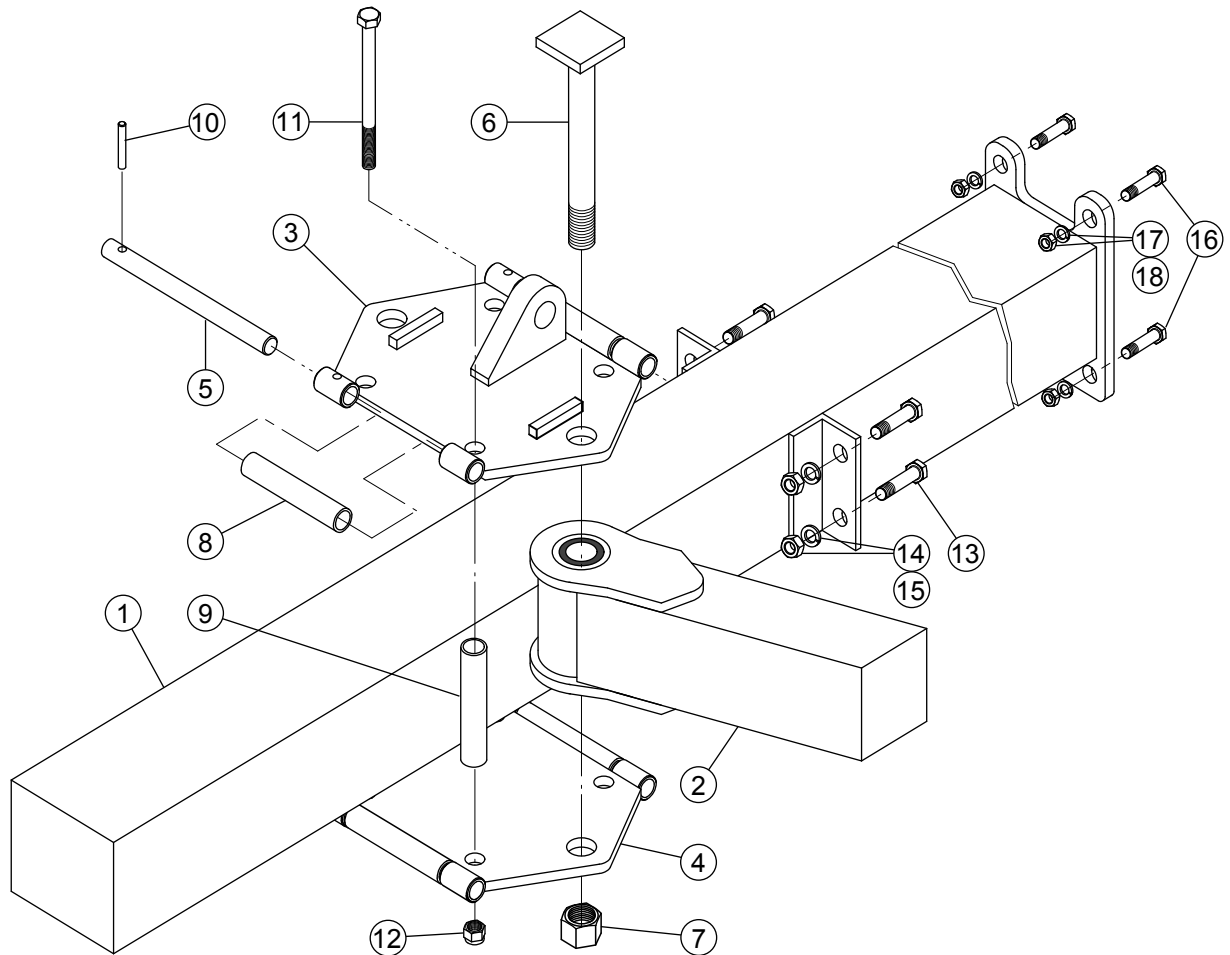

Item	Part Number	Description	Q'ty
1	SVT-00B3000	Rear Tube	1
2	SVT-00C200	Secondary Brace	2
3	SVT-00E100	Top Sliding Plate	1
4	SVT-00E200	Bottom Sliding Plate	1
5	SVT-00E400	Sliding Plate Roller Pin	4
6	SVT-00J300	Brace to Sliding Plate Pin	2
7	NYNUT-20NC	1-1/4" NC Nylon Lock Hex Nut	2
8	SVT-00E300	Sliding Plate Roller	4
9	SVT-00E500	Sliding Plate Spacer	4
10	GPN-05X40R	5/16" X 2-1/2" Roll Pin	4
11	CSNC510144	5/8" X 9" NC Cap Screw	4
12	NYNUT-10NC	5/8" NC Nylon Lock Hex Nut	4
13	CSNC512040	3/4" X 2-1/2" NC Cap Screw	4
14	LWASHER-12	3/4" Lock Washer	4
15	HXNUT-12NC	3/4" NC Hex Nut	4
16	CSNC510032	5/8" X 2" NC Cap Screw	4
17	LWASHER-10	5/8" Lock Washer	4
18	HXNUT-10NC	5/8" NC Hex Nut	4

**Dual Tire Wheel Frame Assembly**

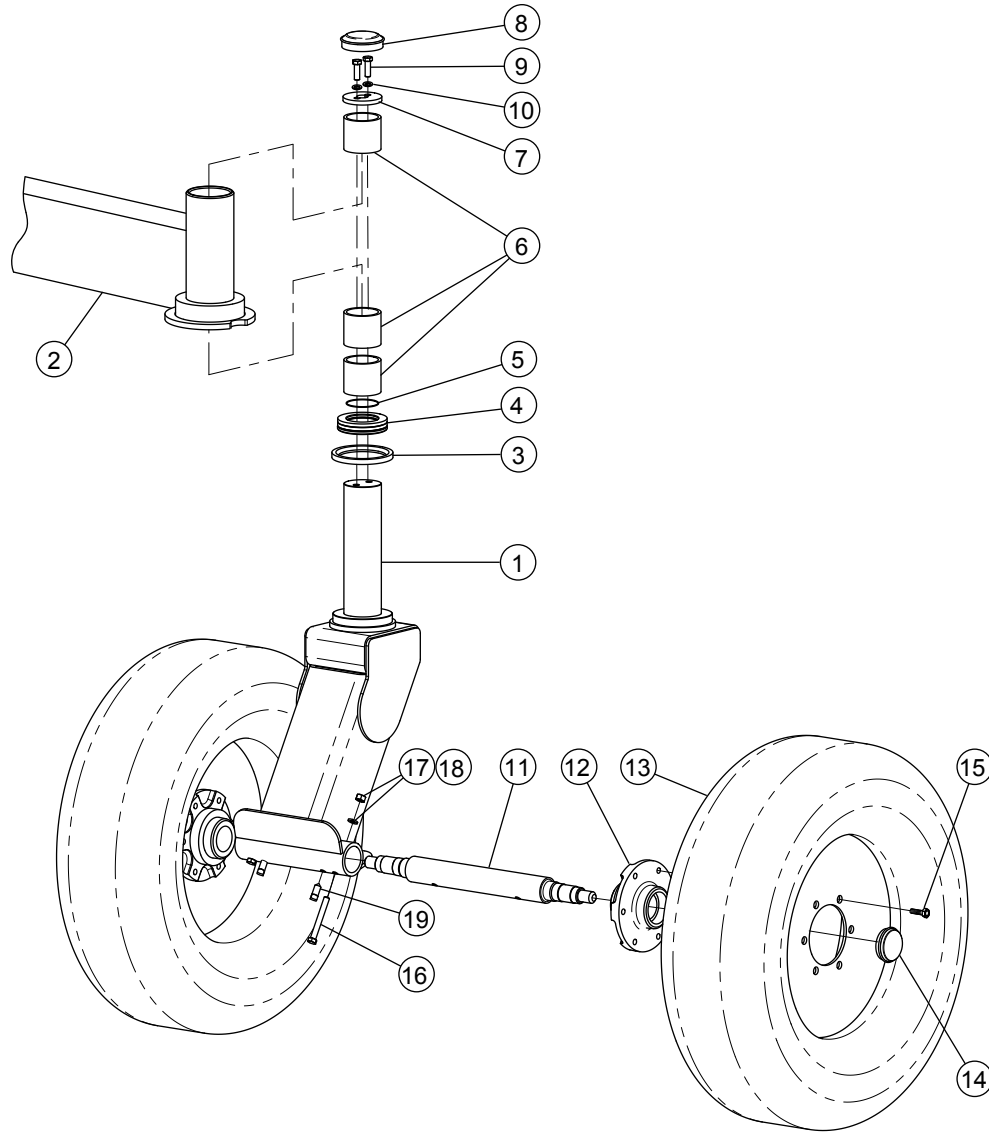

##	Part Number	Description	Q'ty
1	SVT-00G100	Dual Wheel Frame Wldm.	2
	SLP-00N201	Pivot Shaft only	2
2	SVT-00C100	Main Brace	2
3	GBR-47394S	Oil Seal	2
4	GBR-48TB01	Thrust Bearing	2
5	GMB-ORING46	O-Ring	2
6	GBR-4856GB	Housing Bushing	6
7	SLP-00A603	Shaft Cap	2
8	GBR-00GC01	Housing Dust (Grease)Cap	2
9	CSNC808024	1/2" X 1-1/2" Gr.8 Bolts	4

##	Part Number	Description	Q'ty
10	LWASHER-08	1/2" Lock Washer	4
11	TBU-01G016	2" X 20-1/4" Removable Spindle	2
12	GHB-6X6STD	Hub, 6 on 6 Std. Complete	4
13	GWT-951508	9.5 X 15 8 Ply Tire with Wheel	4
14	GHB-6X6CAP	Dust Cap for 6 on 6 Std. Hub	4
15	WHB-08X016	1/2" Wheel Bolt for 6 on 6 Std. Hub	24
16	CSNC507056	7/16" X 3-1/2" NC Cap Screw	4
17	LWASHER-07	7/16" Lock Washer	4
18	HXNUT-07NC	7/16" Hex Nut	4
19	SSNCS08X16	1/2" X 1" NC Set Screw	4



**Rear Single Tire / Steel Wheel Frame Assembly**

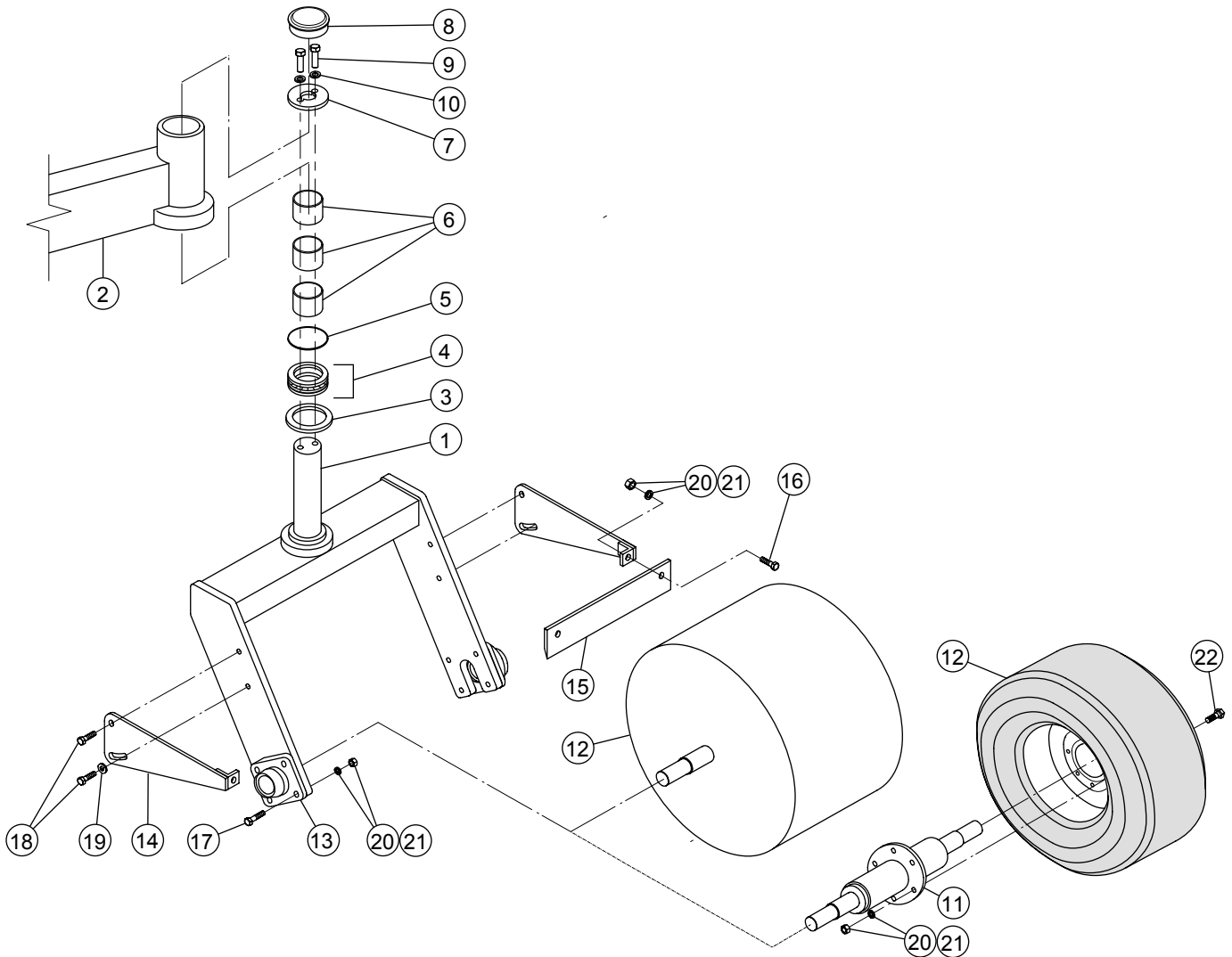

##	Part Number	Description	Q'ty
1	SVT-00G000	Steell Wheel Frame Wldm.	2
	SLP-00N201	Pivot Shaft only	2
2	SVT-00C100	Main Brace	2
3	GBR-47394S	Oil Seal	2
4	GBR-48TB01	Thrust Bearing Assembly	2
5	GMB-ORING46	O-Ring	2
6	GBR-4856GB	Housing Bushing	6
7	SLP-00A603	Shaft Cap	2
8	GBR-00GC01	Housing Dust (Grease)Cap	2
9	CSNC808024	1/2" X 1-1/2" Gr.8 Bolts	4
10	LWASHER-08	1/2" Lock Washer	4
11	SVT-00H000	Tire Mount (Single Tire Option)	2

##	Part Number	Description	Q'ty
12	SLP-00D000	30" Steel Wheel (Steel Wheel Option)	2
	GWT-111408	11L X 14 Tire w/Wheel (Single Tire Opt)	2
13	TPP3152	1-11/16" Flange Bearing	4
14	SLP-00B200L	Scraper Blade Arm LH (Steel Wheel Opt)	2
	SLP-00B200R	Scraper Blade Arm RH (Steel Wheel Opt)	2
15	SLP-00B203	Rear Wheel Scraper Blade (Steel Wheel)	2
16	CSNC508024	1/2" X 1-1/2" NC Gr.5 Cap Screw	4
17	CSNC508036	1/2" X 2-1/4" NC Gr.5 Cap Screw	16
18	CSNC508032	1/2" X 2" NC Gr.5 Cap Screw (Steel Wh)	8
19	FWASHER-08	1/2" Flat Washer (Steel Wheel Option)	4
20	LWASHER-08	1/2" Lock Washer	24
21	HXNUT-08NC	1/2" NC Hex Nut	24
22	WHB-08X016	1/2" X 1" Wheel Bolt (Single Tire Option)	12

**Wing Bucket Assembly**

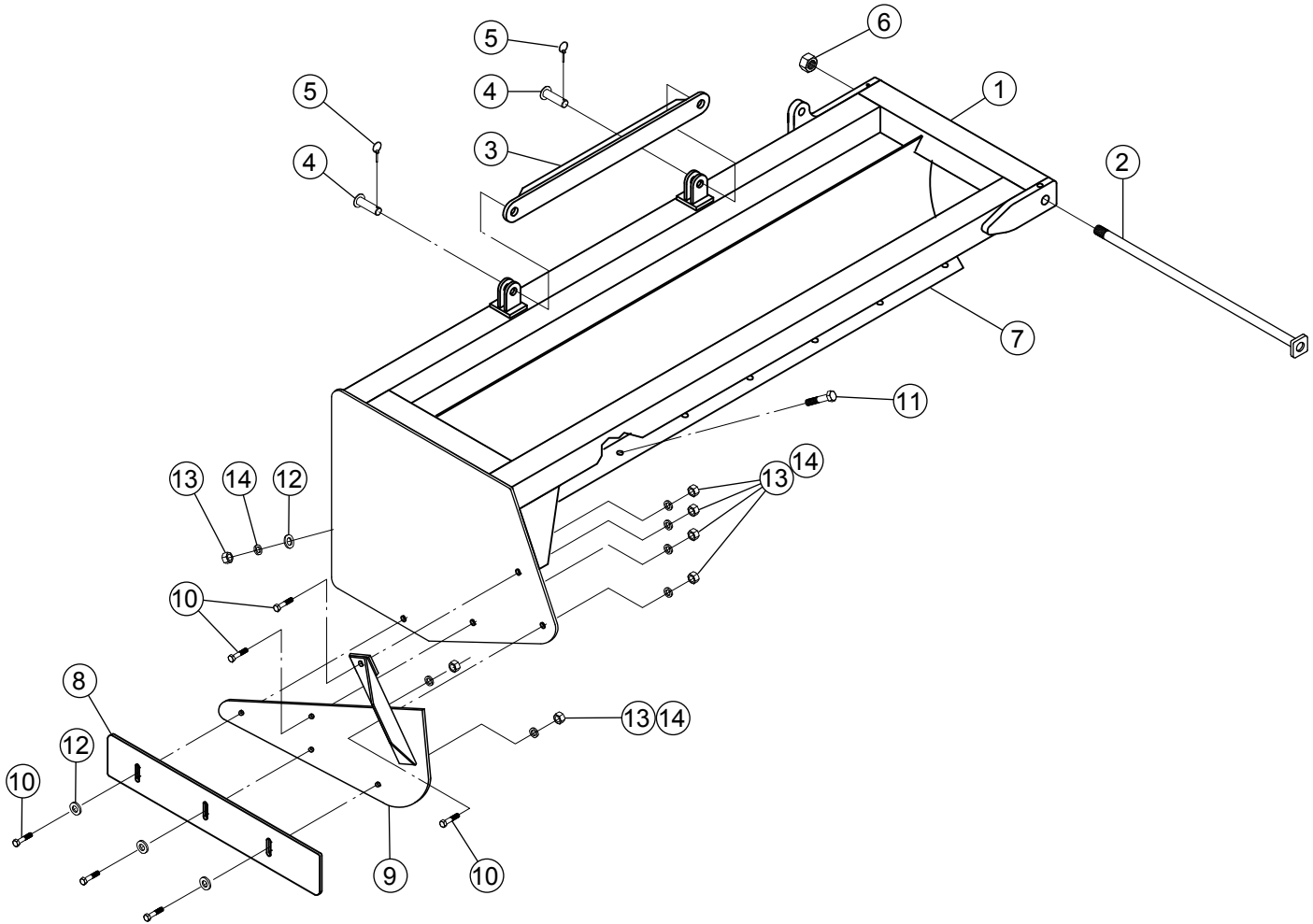

##	Part Number	Description	Q'ty per pair
1	SVT-06D100	6 Ft. Wings (pair)	1
	SVT-08D100	8 Ft. Wings (pair)	1
	SVT-10D100	10 Ft. Wings (pair)	1
2	SVT-00J100	Wing Hinge Pin	2
3	SVT-00D200	Wing Transport Lockout	2
4	GPN-16X040	1" X 2-1/2" General Clevis Pin	4
5	GPN-040LYN	1/4" Lynch Pin	4
6	HXNUT-20NC	1-1/4" NC Nylon Lock Hex Nut	8
7	SVT-BK3824	Blade Kit for 24 Ft. Unit (includes all blades and fasteners)	1
	SVT-BK3830	Blade Kit for 30 Ft. Unit (includes all blades and fasteners)	1
8	SLP-00L204	Bucket Side Adjustment Blade	2
9	SLP-00L200L	Bucket Side LH	1
	SLP-00L200R	Bucket Side RH	1
10	CSNC5010032	5/8" X 2" Gr.5 NC Cap Screw	12
11	PBNC-10028	5/8" X 1-3/4" NC Plow Bolt	18
12	FWASHER-10	5/8" Flat Washer	24
13	HXNUT-10NC	5/8" NC Hex Nut	30
14	LWASHER-10	5/8" Lock Washer	30

**Rear Braces Assembly**

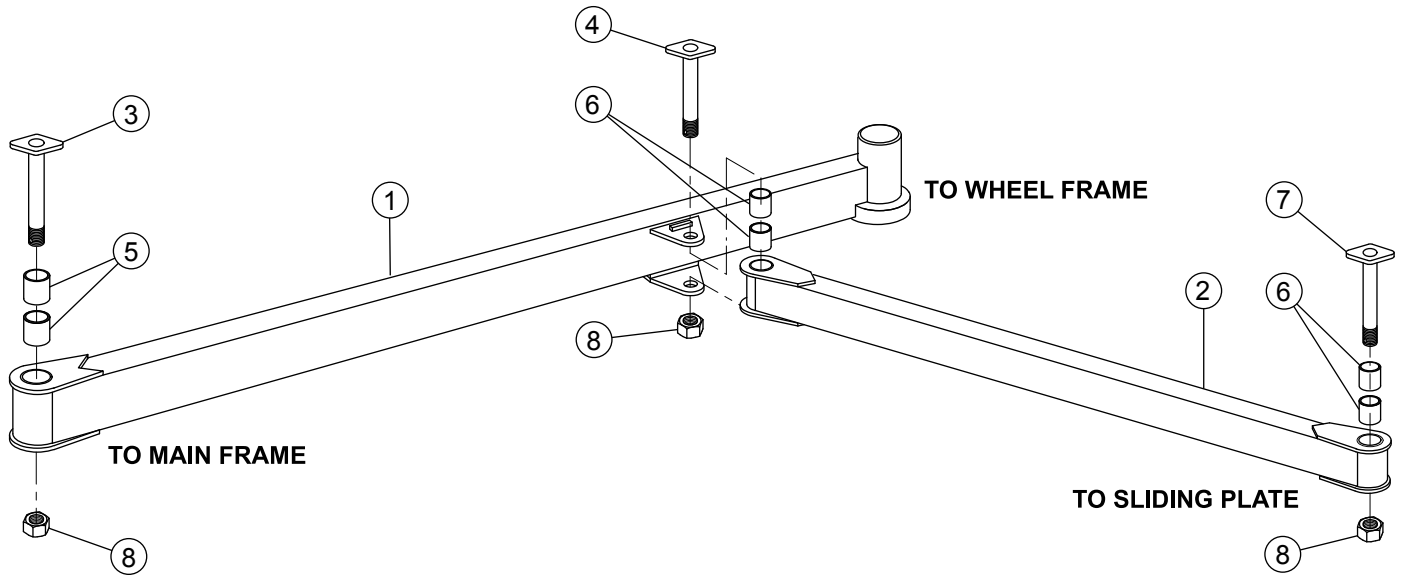

##	Part Number	Description	Q'ty
1	SVT-00C100	Primary Brace	2
2	SLP-00C200	Secondary Brace	2
3	SVT-00J400	1-1/4" X 11" Brace to Main Frame Pin	2
4	SVT-00J200	1-1/4" X 8-1/2" Brace to Brace Pin	2
5	GBR-2024G64	1-1/4" X 1-1/2" X 4" Self-Lubricating Bushing	4
6	GBR-2024G48	1-1/4" X 1-1/2" X 3" Self-Lubricating Bushing	8
7	SVT-00J300	1-1/4" X 8-3/4" Brace to Sliding Plate Pin	2
8	NYNUT-20NC	1-1/4" NC Nylon Lock Hex Nut	8

**S-Tine Attachment Assembly (Optional)**

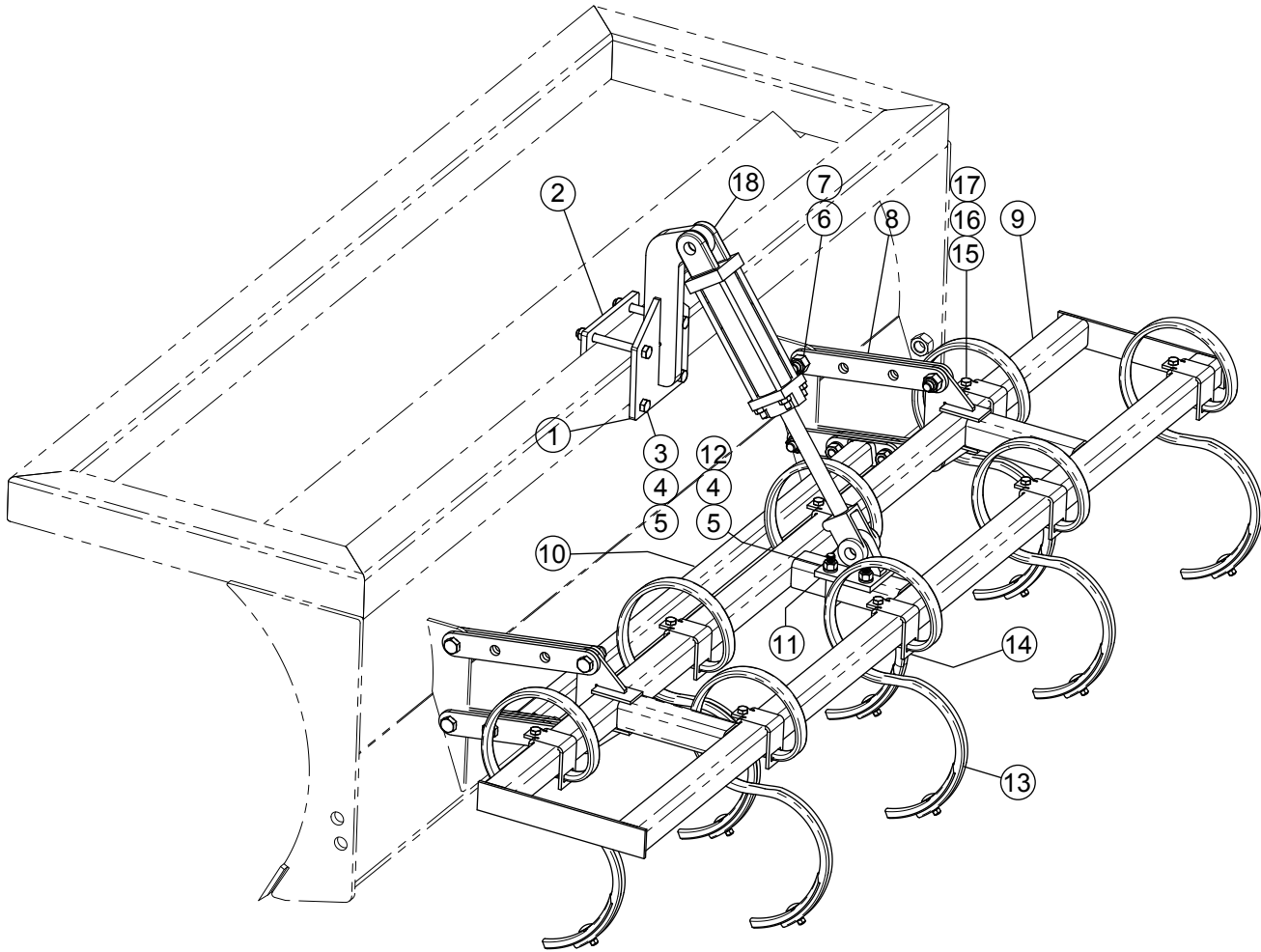

##	Part Number	Description	Q'ty/ Bucket
1	SVT-00L500	Cylinder Anchor Large	1
2	SLP-00L503	Cylinder Anchor Clamp Pl.	1
3	CSNC510096	5/8" X 6" NC Gr.5 Cap Screw	4
4	LWASHER-10	5/8" Lock Washer	8
5	HXNUT-10NC	5/8" NC Hex Nut	8
6	CSNC512040	3/4" X 2-1/2" NC Gr.5 Cap Screw	8
7	NYNUT-12NC	3/4" NC Nylon Lock Hex Nut	8
8	SVT-00L400	S-Tine Attachment Link	8
9	SVT-06L200	6 Ft. S-Tine Attachment Frame	3
	SVT-08L200	8 Ft. S-Tine Attachment Frame	3
	SVT-10L200	10 Ft. S-Tine Attachment Frame	3

##	Part Number	Description	Q'ty/ Bucket
10	SVT-00L300	S-Tine Attachment Spacer Brace	1 or 2
11	SVT-00L100	Cylinder Anchor Small	1
12	UBNC10X41S	5/8" NC Square U-Bolt	2
13	GST-50125S	1/2" X 1-1/4" S-Tine Std (includes point)	varies
14	GST-2CL250	2-1/2" S-Tine Bar Clamp	varies
15	CBNC508064	1/2" X 4" NC Carriage Bolt	varies
16	LWASHER-08	1/2" Lock Washer	varies
17	HXNUT-08NC	1/2" NC Hex Nut	varies
18	-----	Series Hydraulic Cylinder (see p. for installation details and all part numbers)	1 of ea

**S-Tine Attachment Parallel Links Assembly (Optional)**

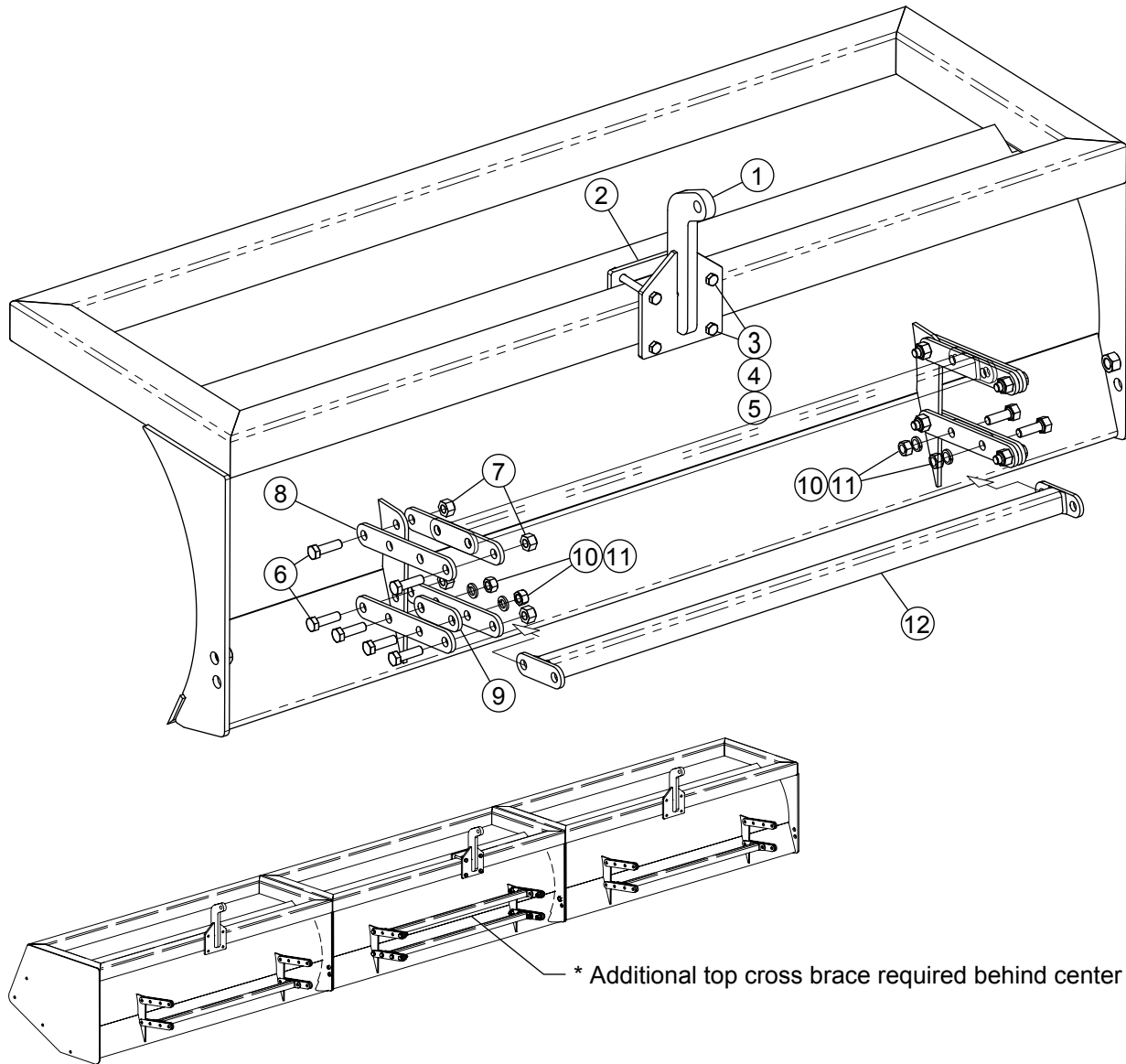

##	Part Number	Description	Q'ty/ Wing Bucket	Q'ty/ Center Bucket *
1	SVT-00L500	Cylinder Anchor Large	1	1
2	SLP-00L503	Cylinder Anchor Clamp Pl.	1	1
3	CSNC510096	5/8" X 6" NC Gr.5 Cap Screw	4	4
4	LWASHER-10	5/8" Lock Washer	4	4
5	HXNUT-10NC	5/8" NC Hex Nut	4	4
6	CSNC512040	3/4" X 2-1/2" NC Gr.5 Cap Screw	12	16
7	NYNUT-12NC	3/4" NC Nylon Lock Hex Nut	8	8
8	SVT-00L400	S-Tine Attachment Link	8	8
9	SVT-00L302	S-Tine Attachment Spacer Plate	2	4
10	LWASHER-12	3/4" Lock Washer	4	8
11	HXNUT-12NC	10 Ft. S-Tine Attachment Frame	4	8
12	SVT-00L300	S-Tine Attachment Spacer Brace	1	2



**S-Tine Assembly (Optional)**

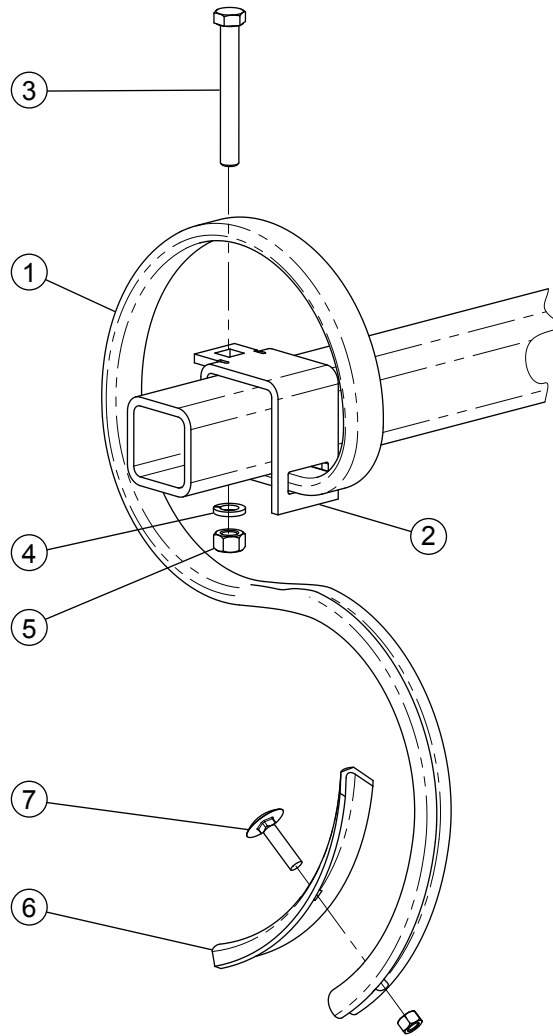

##	Part Number	Description	Q'ty/ S-Tine
1	GST-50125S	S-Tine Assembly (includes point)	1
2	GST-2CL250	2-1/2" S-Tine Bar Clamp	1
3	CBNC508064	1/2" X 4" NC Round Head Square Neck Bolt	1
4	LWASHER-08	1/2" Lock Washer	1
5	HXNUT-08NC	1/2" NC Hex Nut	1
6	GST-25150P	1/4" Standard S-Tine Point (replacement)	1
7	GST-0624BN	3/8" X 1-1/2" Elliptical Head Plow Bolt s/Nut (replacement)	1



## HYDRAULIC DIAGRAMS

### Main Hydraulic Diagram

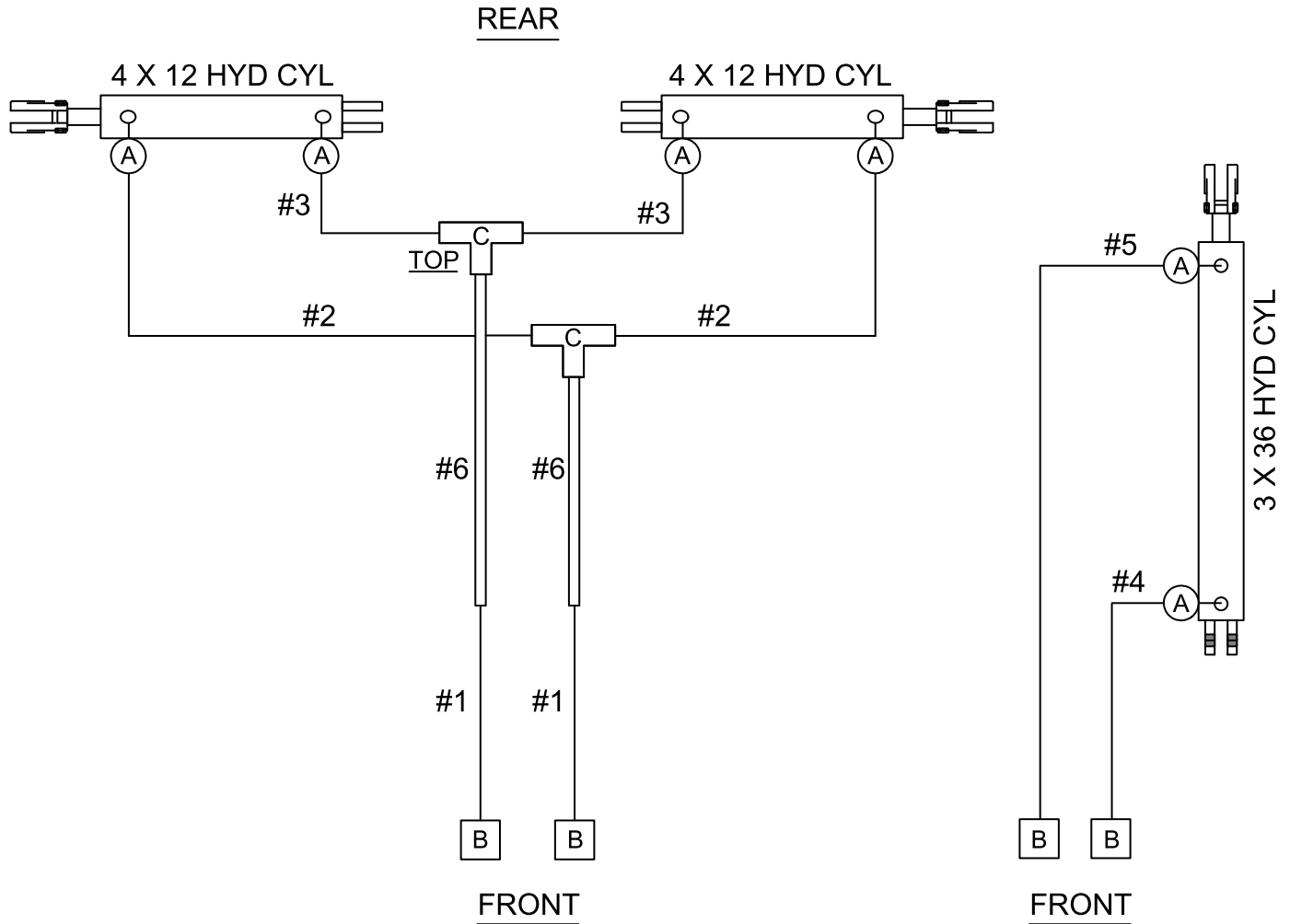

Item	Part Number	Description	Qty.
<b>Hydraulic Cylinders</b>			
	GHC-40120T	4" x 12" Tie Rod Cylinder	2
	GHC-30360T	3" x 36" Tie Rod Cylinder	1
<b>Fittings</b>			
A	FMBMJ9088	8MB-8MJ 90° Elbow	6
B	FFP08000PT	1/2" Pioneer Tip	4
C	FMJT08	8MJ Tee	2
<b>Hoses</b>			
#1	8MP-8MJ 80" Long - Lead Hoses		2
#2	8FJX-8FJX 36" Long		2
#3	8FJX-8FJX 30" Long		2
#4	8MP-8FJX 104" Long - Lead Hose		1
#5	8MP-8FJX 140" Long - Lead Hose		1
#6	1/2" Hydraulic Line 47" Long		2

**Hydraulic S-Tine Cylinder Diagram**

REAR RH WING

2-1/2" X 8" HYD CYL

REAR MAIN FRAME

2-3/4" X 8" HYD CYL

REAR LH WING

3" X 8" HYD CYL

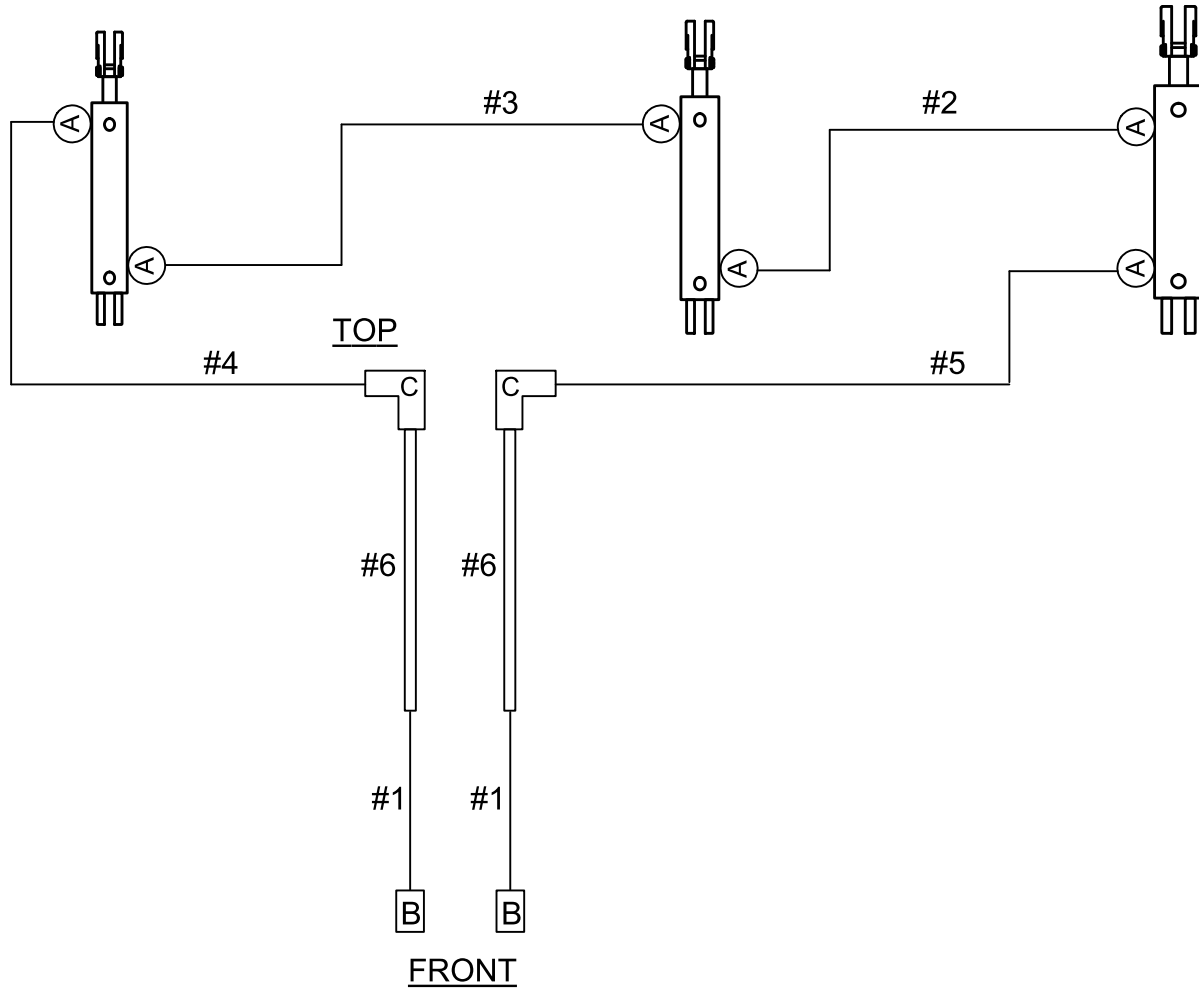

Item	Part Number	Description	Qty.
<b>Hydraulic Cylinders</b>			
	GHC-3008MS	3" X 8" Series Tie Rod Cylinder	1
	GHC-2758MS	2-3/4" X 8" Series Tie Rod Cylinder	1
	GHC-2508MS	2-1/2" X 8" Series Tie Rod Cylinder	1
<b>Fittings</b>			
A	FMBMJ9088	8MB-8MJ 90° Elbow	6
B	FFP08000PT	1/2" Pioneer Tip	2
C	FMJMJ9088	8MJ-8MJ 90° Elbow	2
<b>Hoses</b>			
#1	8MP-8MJ 80" Long - Lead Hoses		2
#2	8FJX-8FJX 143" Long		1
#3	8FJX-8FJX 84" Long		2
#4	8FJX-8FJX 120" Long		1
#5	8FJX-8FJX 108" Long		1
#6	1/2" Hydraulic Line 47" Long		2







## LIMITED WARRANTY STATEMENT

### T.G. Schmeiser Co., Inc.

P.O. Box 1392 – Selma, CA 93662

Phone (559) 268-8128 Fax (559) 268-3279

T. G. Schmeiser Co., Inc. warrants each new Schmeiser® product to be free from defects in material and workmanship. This warranty is applicable only for the normal service life expectancy of the product or components, not to exceed twelve (12) consecutive months from the date of delivery of the new Schmeiser product to the original purchaser.

Genuine T. G. Schmeiser Co., Inc. replacement parts and components will be warranted for 90 days from date of purchase, or the remainder of the original equipment warranty period, whichever is longer.

Under no circumstances will it cover any merchandise or components thereof, which, in the opinion of the company, has been subjected to misuse, unauthorized modifications, alteration, an accident or if repairs have been made with parts other than those obtainable through T. G. Schmeiser Co., Inc.

The Company in no way warrants engines, batteries, cylinders, tires or other trade accessories since these items are warranted separately by their respective manufacturer. Expendable components such as points, shanks, blades, rings, bearings, teeth, and the like are excluded from this warranty.

Our obligation under this warranty shall be limited to repairing or replacing, free of charge to the original purchaser, any part that, in our judgment, shall show evidence of such defect, provided further that such part shall be returned within thirty (30) days from date of failure to T. G. Schmeiser Co., Inc., routed through the dealer and distributor from whom the purchase was made, transportation charges prepaid.

This warranty shall not be interpreted to render T. G. Schmeiser Co., Inc. liable for injury or damages of any kind or nature to person or property. This warranty does not extend to the loss of crops, loss because of delay in harvesting, or any expense or loss incurred for labor, substitute machinery, rental or for any other reason.

Except as set forth above, **T. G. Schmeiser Co., Inc. shall have no obligation or liability of any kind on account of any of its equipment and shall not be liable for special or consequential damages. T. G. Schmeiser Co., Inc. makes no other warranty, expressed or implied, and, specifically, T. G. Schmeiser Co., Inc. disclaims any implied warranty or merchantability or fitness for a particular purpose. Some states or provinces do not permit limitations or exclusions of implied warranties or incidental or consequential damages, so the limitations or exclusion in this warranty may not apply.**

This warranty is subject to any existing conditions of supply, which may directly affect our ability to obtain materials or manufacture replacement parts.

T. G. Schmeiser Co., Inc. reserves the right to make improvements in design or changes in specifications at any time, without incurring any obligation to owners of units previously sold.

No one is authorized to alter, modify or enlarge this warranty nor the exclusion, limitations and reservations.

**WARRANTY VOID IF NOT REGISTERED  
WITHIN 30 DAYS OF PURCHASE DATE**



**P.O. Box 1392  
Selma, CA 93662  
(559) 268-8128  
WEB: [www.TGSchmeiser.com](http://www.TGSchmeiser.com)**

